

IF AFTER TROUBLESHOOTING A PROBLEM, A SATISFACTORY SOLUTION CANNOT BE ACHIEVED, PLEASE CALL B.E.A., INC. FOR FURTHER ASSISTANCE DURING EASTERN STANDARD TIME AT 1-800-523-2462 FROM 8AM - 5PM. FOR AFTER-HOURS, CALL EAST COAST: 1-866-836-1863 OR 1-800-407-4545 / MID-WEST: 1-888-308-8843 / WEST COAST: 1-888-419-2564. DO NOT LEAVE ANY PROBLEM UNRESOLVED. IF YOU MUST WAIT FOR THE FOLLOWING WORKDAY TO CALL B.E.A., LEAVE THE DOOR INOPERABLE UNTIL SATISFACTORY REPAIRS CAN BE MADE. NEVER SACRIFICE THE SAFE OPERATION OF THE AUTOMATIC DOOR OR GATE FOR AN INCOMPLETE SOLUTION. WEB: WWW.BEASENSORS.COM



100 ENTERPRISE DRIVE
 PITTSBURGH, PA 15275
 PHONE: (412) 249-4100
 FAX: (412) 249-4101
 EMAIL: www.beasensors.com

**TITLE: WIZARD WITH MC25
 STANLEY DURAGLIDE CONTROL**

SIZE: A	DRAWN BY: KJG	REV BY: TUC	PART NO: 80.0117.02
	SCALE: NONE	DATE: 21 NOV 2005	SHEET 1 OF 1

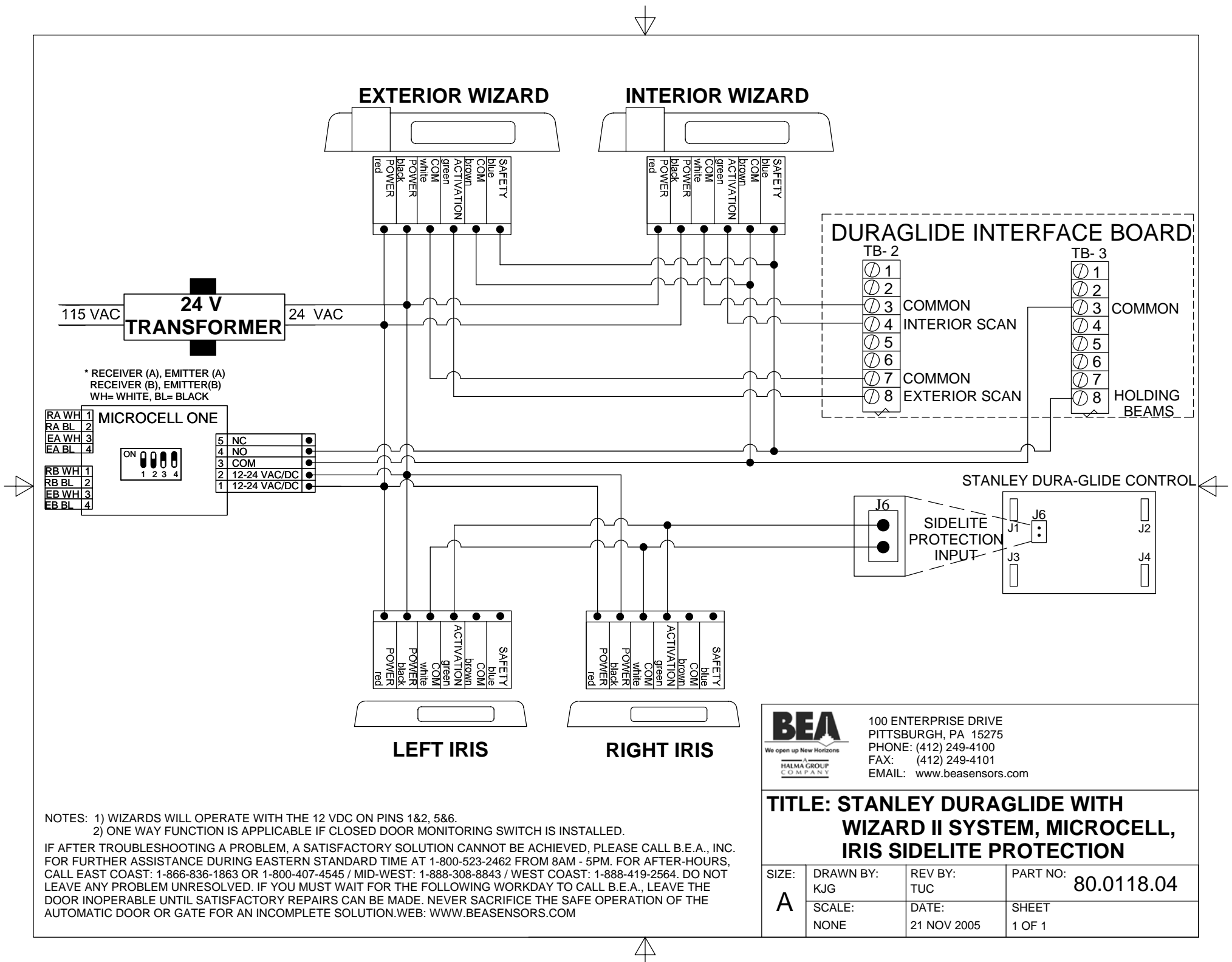

EXTERIOR WIZARD

INTERIOR WIZARD

DURAGLIDE INTERFACE BOARD

24 V TRANSFORMER

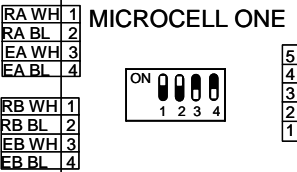

LEFT IRIS

RIGHT IRIS

STANLEY DURA-GLIDE CONTROL



100 ENTERPRISE DRIVE
 PITTSBURGH, PA 15275
 PHONE: (412) 249-4100
 FAX: (412) 249-4101
 EMAIL: www.beasensors.com

TITLE: STANLEY DURAGLIDE WITH WIZARD II SYSTEM, MICROCELL, IRIS SIDELITE PROTECTION

SIZE: A	DRAWN BY: KJG	REV BY: TUC	PART NO: 80.0118.04
	SCALE: NONE	DATE: 21 NOV 2005	SHEET 1 OF 1

NOTES: 1) WIZARDS WILL OPERATE WITH THE 12 VDC ON PINS 1&2, 5&6.
 2) ONE WAY FUNCTION IS APPLICABLE IF CLOSED DOOR MONITORING SWITCH IS INSTALLED.
 IF AFTER TROUBLESHOOTING A PROBLEM, A SATISFACTORY SOLUTION CANNOT BE ACHIEVED, PLEASE CALL B.E.A., INC. FOR FURTHER ASSISTANCE DURING EASTERN STANDARD TIME AT 1-800-523-2462 FROM 8AM - 5PM. FOR AFTER-HOURS, CALL EAST COAST: 1-866-836-1863 OR 1-800-407-4545 / MID-WEST: 1-888-308-8843 / WEST COAST: 1-888-419-2564. DO NOT LEAVE ANY PROBLEM UNRESOLVED. IF YOU MUST WAIT FOR THE FOLLOWING WORKDAY TO CALL B.E.A., LEAVE THE DOOR INOPERABLE UNTIL SATISFACTORY REPAIRS CAN BE MADE. NEVER SACRIFICE THE SAFE OPERATION OF THE AUTOMATIC DOOR OR GATE FOR AN INCOMPLETE SOLUTION.WEB: WWW.BEASENSORS.COM



N.C.	5
N.O.	4
COM	3
POWER 2	2
POWER 1	1

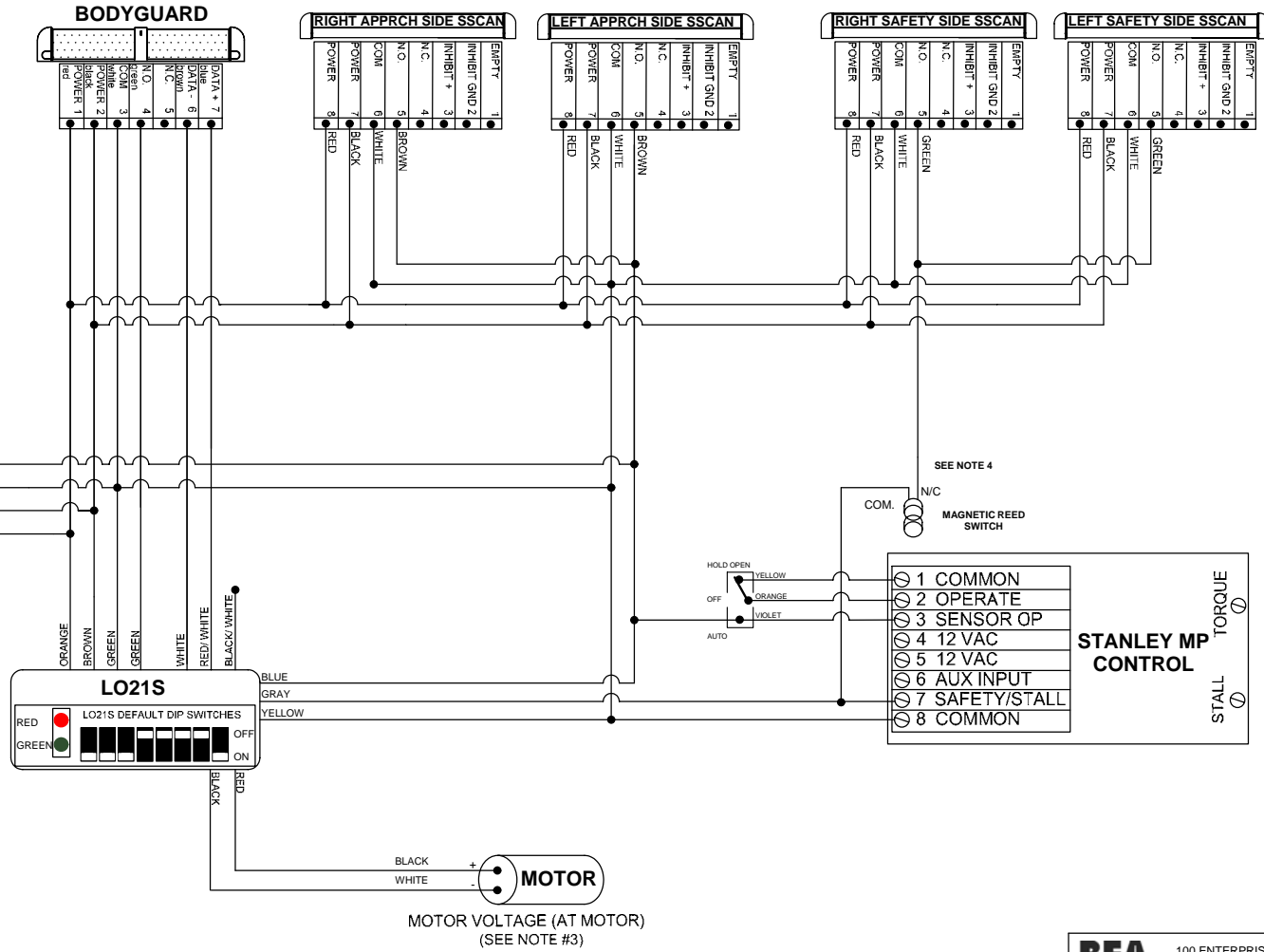

MOTOR VOLTAGE (AT MOTOR)
(SEE NOTE #3)

- NOTES: 1) DOOR CONTROL SW2 SWITCH BANK SET DIPSWITCH # 1 & 3 TO THE OFF (TIMER) POSITION.
 2) TORQUE IF APPLICABLE AND STALL ADJUSTMENTS MAY NEED TO BE INCREASED FOR LO21S PROPER OPERATION.
 3) SHOWN LH,RH MAGIC SWING AND RH MAGIC FORCE FOR LH MAGIC FORCE REVERSE LO21S RED AND BLACK WIRES.
 4) IF MAGIC SWITCH USE INHIBIT PART # 10SSINHL OR 10SSINHR. IF MAGIC FORCE USE AUX. CAM SWITCH 4.

IF AFTER TROUBLESHOOTING A PROBLEM, A SATISFACTORY SOLUTION CANNOT BE ACHIEVED, PLEASE CALL B.E.A., INC. FOR FURTHER ASSISTANCE DURING EASTERN STANDARD TIME AT 1-800-523-2462 FROM 8AM - 5PM. FOR AFTER-HOURS, CALL EAST COAST: 1-866-836-1863 OR 1-800-407-4545 / MID-WEST: 1-888-308-8843 / WEST COAST: 1-888-419-2564. DO NOT LEAVE ANY PROBLEM UNRESOLVED. IF YOU MUST WAIT FOR THE FOLLOWING WORKDAY TO CALL B.E.A., LEAVE THE DOOR INOPERABLE UNTIL SATISFACTORY REPAIRS CAN BE MADE. NEVER SACRIFICE THE SAFE OPERATION OF THE AUTOMATIC DOOR OR GATE FOR AN INCOMPLETE SOLUTION.WEB: WWW.BEASENSORS.COM

BEA
 We Open Up New Horizons
 HAMA GROUP COMPANY

100 ENTERPRISE DRIVE
 PITTSBURGH, PA 15275
 PHONE: (412) 249-4100
 FAX: (412) 249-4101
 EMAIL: www.beasensors.com

TITLE: STANLEY MP CONTROL WITH PARALLAX 2 SYSTEM (LO21S) Q-DISCONNECT ON SAFETY

SIZE: B	DRAWN BY: K/JG	REV BY: TUC	PART NO: 80.0121.02
SCALE: NONE	DATE: 22 NOV 2005	SHEET: 1 OF 1	

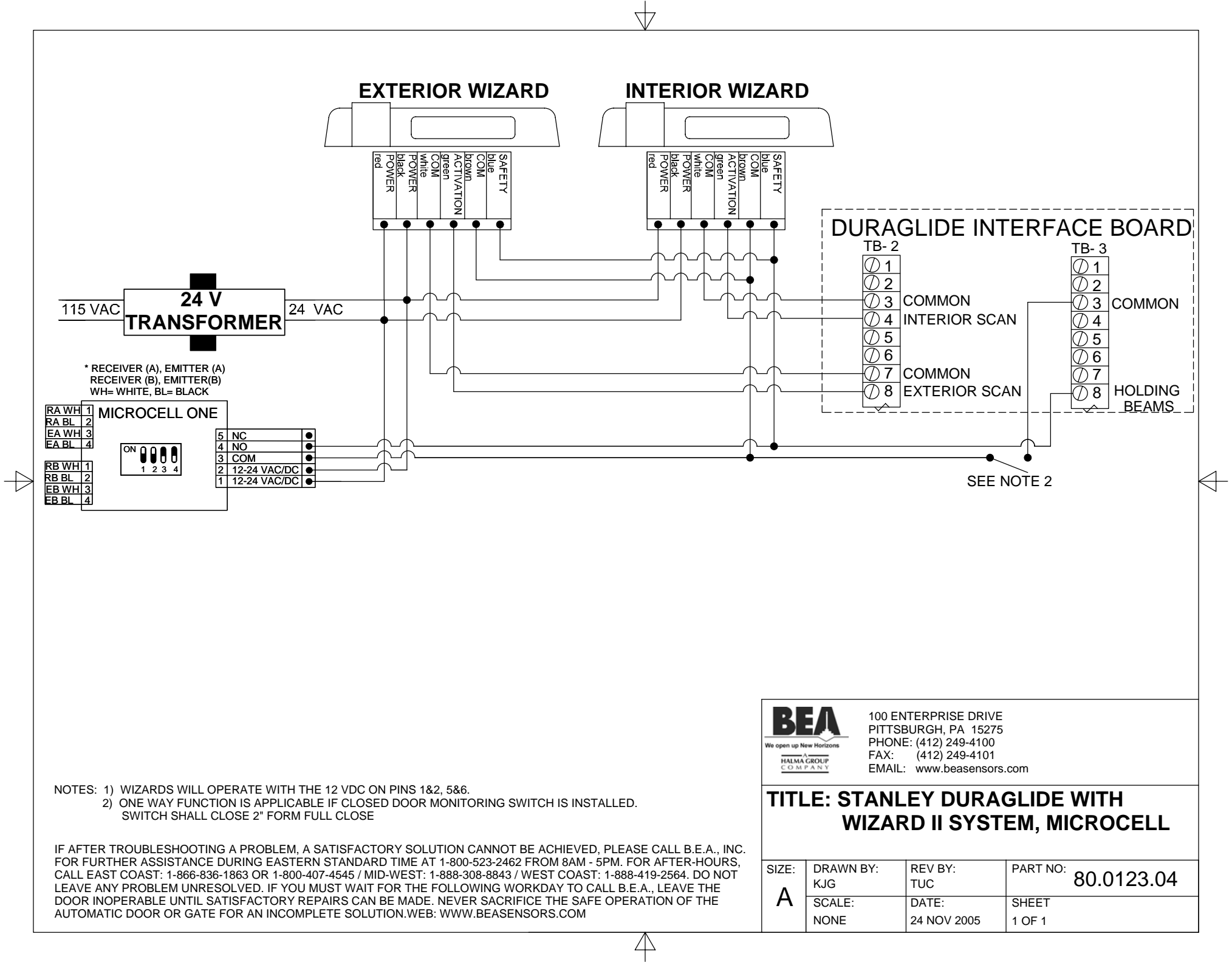

* RECEIVER (A), EMITTER (A)
 RECEIVER (B), EMITTER (B)
 WH= WHITE, BL= BLACK

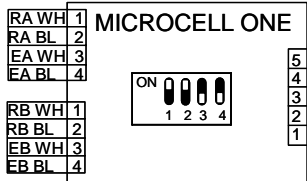

- NOTES: 1) WIZARDS WILL OPERATE WITH THE 12 VDC ON PINS 1&2, 5&6.
 2) ONE WAY FUNCTION IS APPLICABLE IF CLOSED DOOR MONITORING SWITCH IS INSTALLED.
 SWITCH SHALL CLOSE 2" FORM FULL CLOSE

IF AFTER TROUBLESHOOTING A PROBLEM, A SATISFACTORY SOLUTION CANNOT BE ACHIEVED, PLEASE CALL B.E.A., INC. FOR FURTHER ASSISTANCE DURING EASTERN STANDARD TIME AT 1-800-523-2462 FROM 8AM - 5PM. FOR AFTER-HOURS, CALL EAST COAST: 1-866-836-1863 OR 1-800-407-4545 / MID-WEST: 1-888-308-8843 / WEST COAST: 1-888-419-2564. DO NOT LEAVE ANY PROBLEM UNRESOLVED. IF YOU MUST WAIT FOR THE FOLLOWING WORKDAY TO CALL B.E.A., LEAVE THE DOOR INOPERABLE UNTIL SATISFACTORY REPAIRS CAN BE MADE. NEVER SACRIFICE THE SAFE OPERATION OF THE AUTOMATIC DOOR OR GATE FOR AN INCOMPLETE SOLUTION. WEB: WWW.BEASENSORS.COM

BEA
 We open up New Horizons
 A HALMA GROUP COMPANY

100 ENTERPRISE DRIVE
 PITTSBURGH, PA 15275
 PHONE: (412) 249-4100
 FAX: (412) 249-4101
 EMAIL: www.beasensors.com

TITLE: STANLEY DURAGLIDE WITH WIZARD II SYSTEM, MICROCELL

SIZE: A	DRAWN BY: KJG	REV BY: TUC	PART NO: 80.0123.04
	SCALE: NONE	DATE: 24 NOV 2005	SHEET 1 OF 1

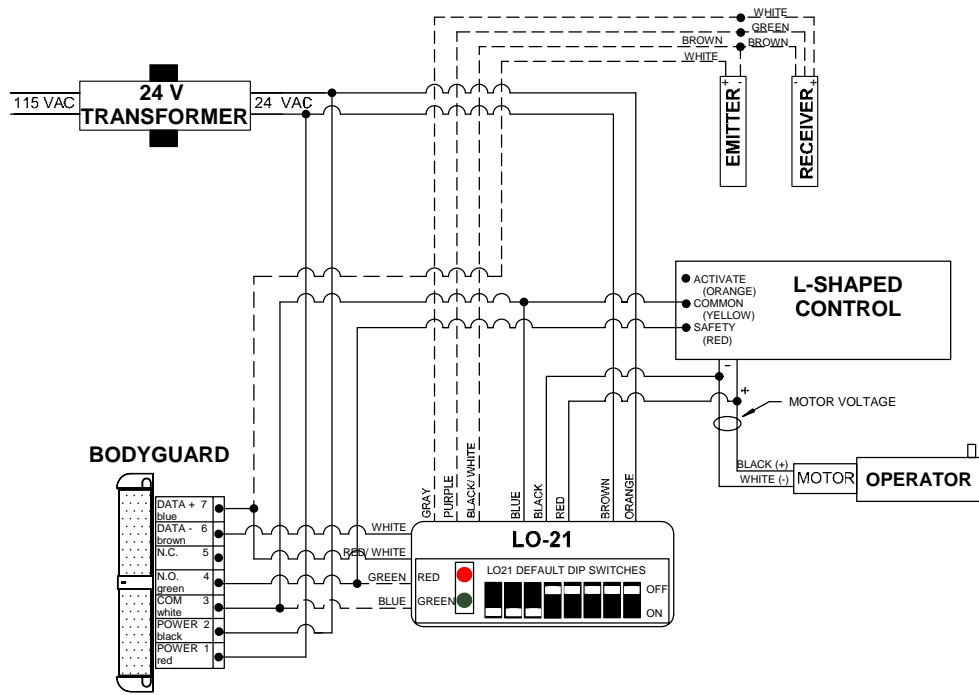

STANLEY 6-PIN CONNECTOR

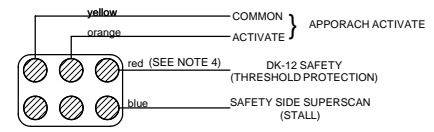

STANLEY 6-PIN CONNECTOR
TAN OR BLACK CONTROL BOX
WITH STALL CAPABILITIES

- NOTES: 1) MAGIC SWING SHOW. LO21/S RED TO MOTOR BLACK. LO21/S TO MOTOR WHITE
 2) THE STALL ADJUSTMENT MAY NEED TO BE INCREASED FOR PROPER OPERATION
 3) WHEN REPLACING AN EXISTING SENTREX SYSTEM, THE NEED FOR AN ADDITIONAL WIRE MAY BE REQUIRED AT THE THRESHOLD PROTECTION PIN TO PROVIDE CARPET LOGIC.
 4) WHEN USING DC VOLTAGE, RESPECT POLARITY: ORANGE: (-) BROWN: (+)

IF AFTER TROUBLESHOOTING A PROBLEM, A SATISFACTORY SOLUTION CANNOT BE ACHIEVED, PLEASE CALL B.E.A., INC. FOR FURTHER ASSISTANCE DURING EASTERN STANDARD TIME AT 1-800-523-2462 FROM 8AM - 5PM. FOR AFTER-HOURS, CALL EAST COAST: 1-866-836-1863 OR 1-800-407-4545 / MID-WEST: 1-888-308-8843 / WEST COAST: 1-888-419-2564. DO NOT LEAVE ANY PROBLEM UNRESOLVED. IF YOU MUST WAIT FOR THE FOLLOWING WORKDAY TO CALL B.E.A., LEAVE THE DOOR INOPERABLE UNTIL SATISFACTORY REPAIRS CAN BE MADE. NEVER SACRIFICE THE SAFE OPERATION OF THE AUTOMATIC DOOR OR GATE FOR AN INCOMPLETE SOLUTION.WEB: WWW.BEASENSORS.COM

		100 ENTERPRISE DRIVE PITTSBURGH, PA 15275 PHONE: (412) 249-4100 FAX: (412) 249-4101 EMAIL: www.beasensors.com	
TITLE: STANLEY TAN/BLACK/SILVER CONTROL WITH LO-21,LO21S, BODYGUARD			
SIZE: B	DRAWN BY: K/JG	REV BY: K/JG	PART NO: 80.0125.03
SCALE: NONE	DATE: 1 DEC 2005	SHEET 1 OF 1	

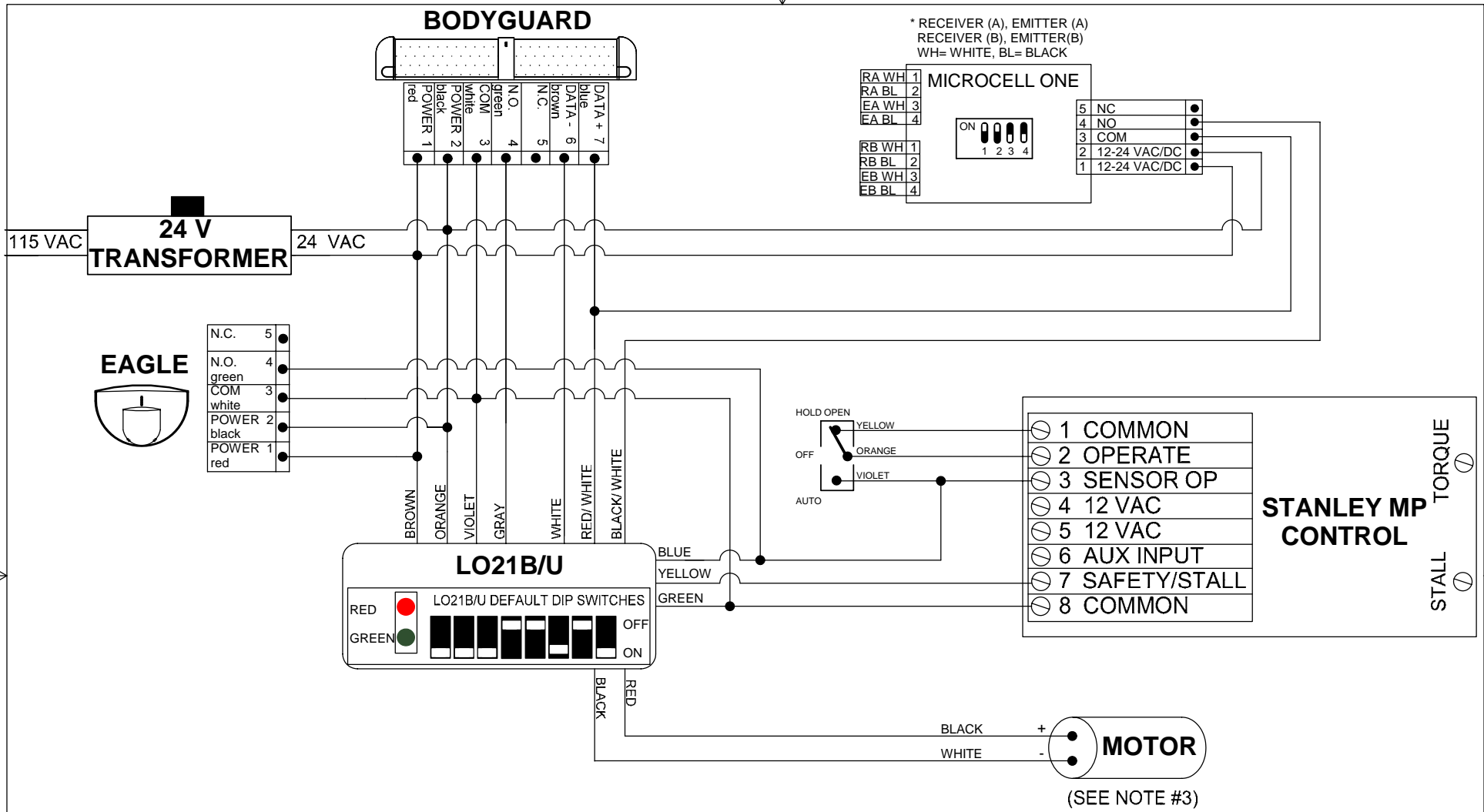

NOTES: 1) LO21U DIPSWITCH SETTINGS #1-5 (LOCK-OUT TIME), #6 (DOWN/ON), #7 (UP/ OFF), #8 (DOWN/ ON).
2) SHOWN LH,RH MAGIC SWING AND RH MAGIC FORCE FOR LH MAGIC FORCE REVERSE LO21B/U RED AND BLACK WIRES.

IF AFTER TROUBLESHOOTING A PROBLEM, A SATISFACTORY SOLUTION CANNOT BE ACHIEVED, PLEASE CALL B.E.A., INC. FOR FURTHER ASSISTANCE DURING EASTERN STANDARD TIME AT 1-800-523-2462 FROM 8AM - 5PM. FOR AFTER-HOURS, CALL EAST COAST: 1-866-836-1863 OR 1-800-407-4545 / MID-WEST: 1-888-308-8843 / WEST COAST: 1-888-419-2564. DO NOT LEAVE ANY PROBLEM UNRESOLVED. IF YOU MUST WAIT FOR THE FOLLOWING WORKDAY TO CALL B.E.A., LEAVE THE DOOR INOPERABLE UNTIL SATISFACTORY REPAIRS CAN BE MADE. NEVER SACRIFICE THE SAFE OPERATION OF THE AUTOMATIC DOOR OR GATE FOR AN INCOMPLETE SOLUTION.WEB: WWW.BEASENSORS.COM



100 ENTERPRISE DRIVE
PITTSBURGH, PA 15275
PHONE: (412) 249-4100
FAX: (412) 249-4101
EMAIL: www.beasensors.com

TITLE: STANLEY MP CONTROL WITH LO21B/U

SIZE: A	DRAWN BY: KJG	REV BY: TUC	PART NO: 80.0127.02
	SCALE: NONE	DATE: 24 NOV 2005	SHEET 1 OF 1

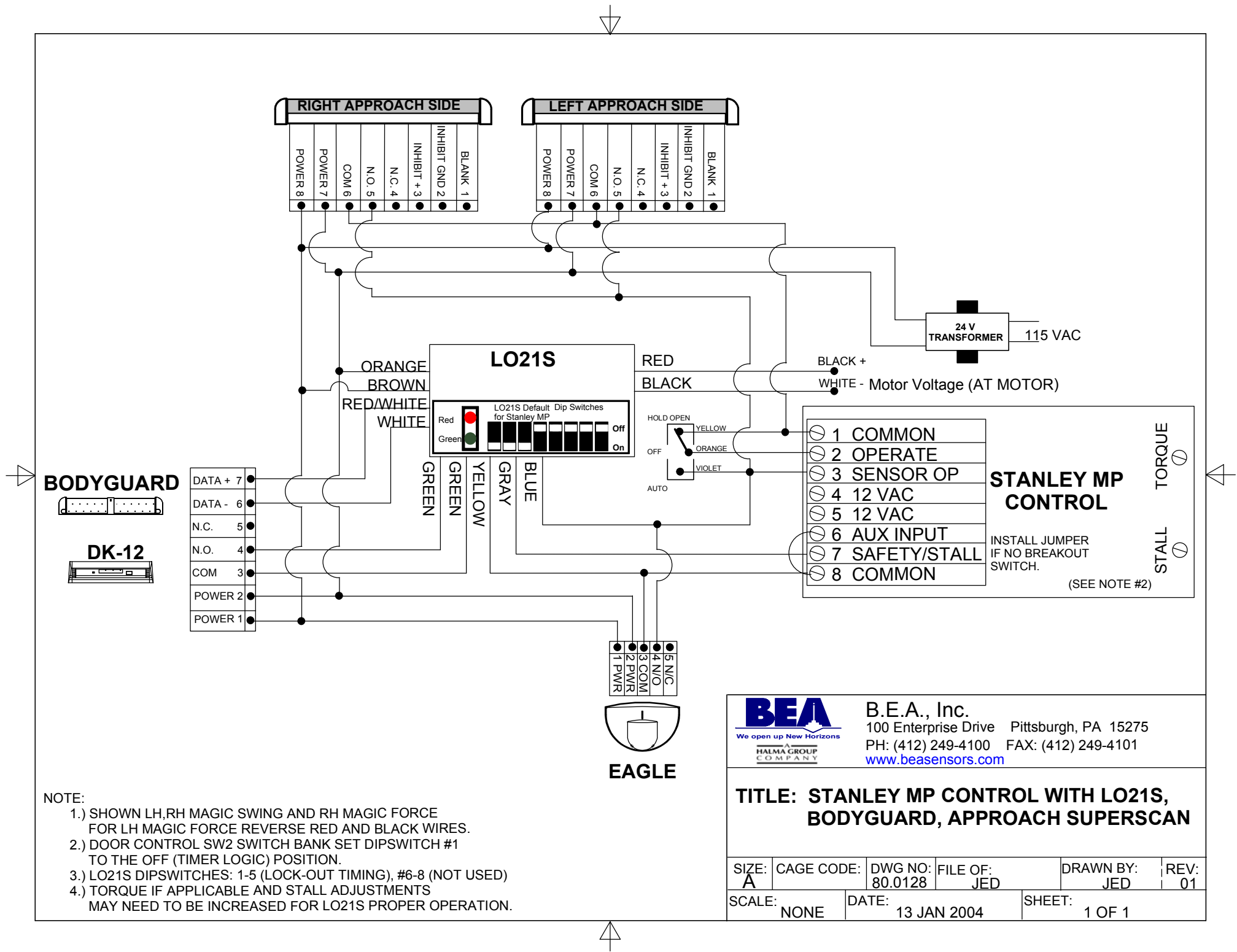

NOTE:

- 1.) SHOWN LH,RH MAGIC SWING AND RH MAGIC FORCE FOR LH MAGIC FORCE REVERSE RED AND BLACK WIRES.
- 2.) DOOR CONTROL SW2 SWITCH BANK SET DIPSWITCH #1 TO THE OFF (TIMER LOGIC) POSITION.
- 3.) LO21S DIPSWITCHES: 1-5 (LOCK-OUT TIMING), #6-8 (NOT USED)
- 4.) TORQUE IF APPLICABLE AND STALL ADJUSTMENTS MAY NEED TO BE INCREASED FOR LO21S PROPER OPERATION.

		B.E.A., Inc. 100 Enterprise Drive Pittsburgh, PA 15275 PH: (412) 249-4100 FAX: (412) 249-4101 www.beasensors.com	
TITLE: STANLEY MP CONTROL WITH LO21S, BODYGUARD, APPROACH SUPERSCAN			
SIZE: A	CAGE CODE:	DWG NO: 80.0128	FILE OF: JED
SCALE: NONE	DATE: 13 JAN 2004	DRAWN BY: JED	REV: 01
SHEET: 1 OF 1			

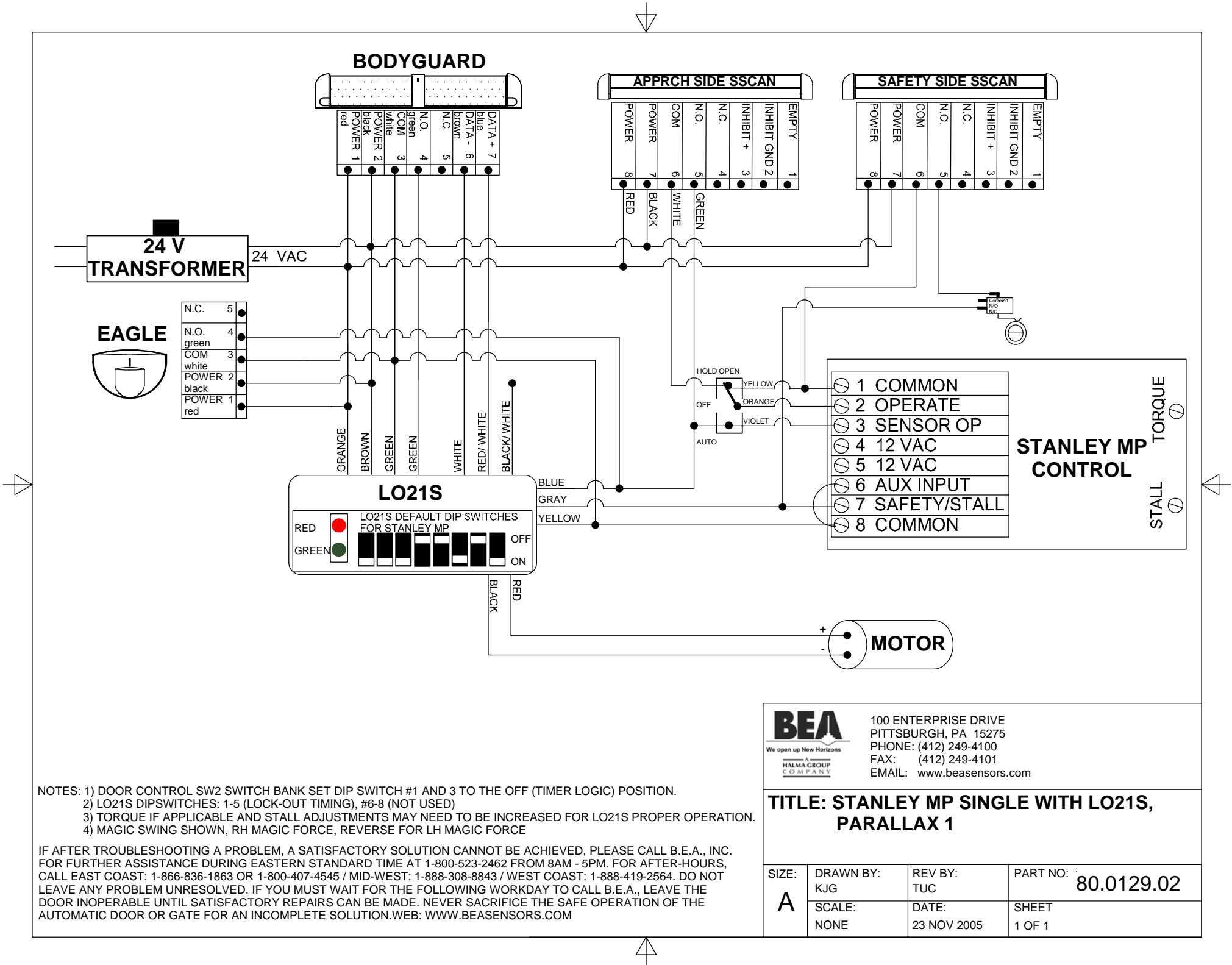

- NOTES: 1) DOOR CONTROL SW2 SWITCH BANK SET DIP SWITCH #1 AND 3 TO THE OFF (TIMER LOGIC) POSITION.
 2) LO21S DIPSWITCHES: 1-5 (LOCK-OUT TIMING), #6-8 (NOT USED)
 3) TORQUE IF APPLICABLE AND STALL ADJUSTMENTS MAY NEED TO BE INCREASED FOR LO21S PROPER OPERATION.
 4) MAGIC SWING SHOWN, RH MAGIC FORCE, REVERSE FOR LH MAGIC FORCE

IF AFTER TROUBLESHOOTING A PROBLEM, A SATISFACTORY SOLUTION CANNOT BE ACHIEVED, PLEASE CALL B.E.A., INC. FOR FURTHER ASSISTANCE DURING EASTERN STANDARD TIME AT 1-800-523-2462 FROM 8AM - 5PM. FOR AFTER-HOURS, CALL EAST COAST: 1-866-836-1863 OR 1-800-407-4545 / MID-WEST: 1-888-308-8843 / WEST COAST: 1-888-419-2564. DO NOT LEAVE ANY PROBLEM UNRESOLVED. IF YOU MUST WAIT FOR THE FOLLOWING WORKDAY TO CALL B.E.A., LEAVE THE DOOR INOPERABLE UNTIL SATISFACTORY REPAIRS CAN BE MADE. NEVER SACRIFICE THE SAFE OPERATION OF THE AUTOMATIC DOOR OR GATE FOR AN INCOMPLETE SOLUTION. WEB: WWW.BEASENSORS.COM

BEA
 We open up New Horizons
 HALMA GROUP
 COMPANY
 100 ENTERPRISE DRIVE
 PITTSBURGH, PA 15275
 PHONE: (412) 249-4100
 FAX: (412) 249-4101
 EMAIL: www.beasensors.com

**TITLE: STANLEY MP SINGLE WITH LO21S,
 PARALLAX 1**

SIZE: A	DRAWN BY: KJG	REV BY: TUC	PART NO: 80.0129.02
	SCALE: NONE	DATE: 23 NOV 2005	SHEET 1 OF 1

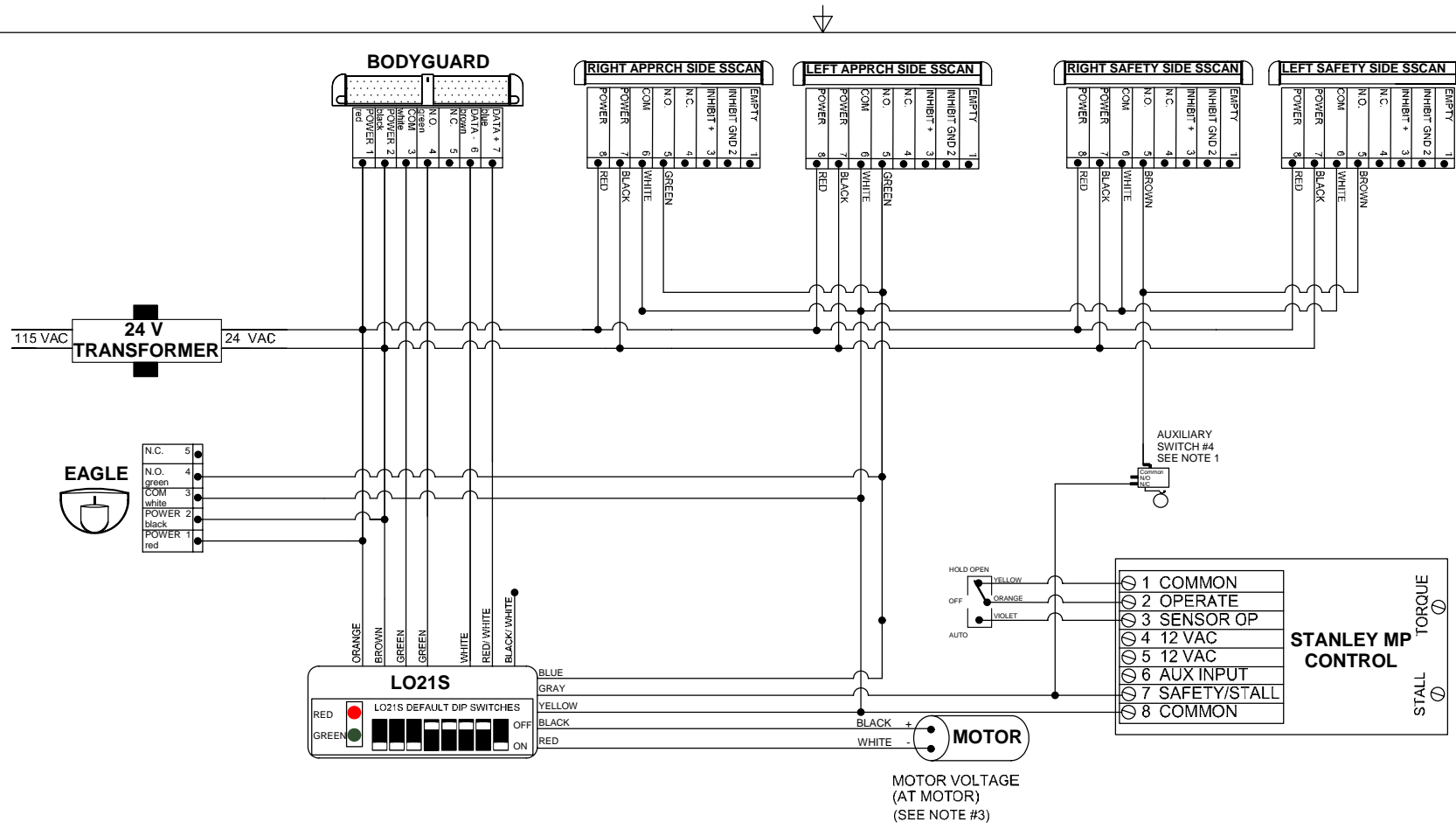

- NOTES: 1) MAGIC FORCE AUX. SWITCH #4 SHOULD OPEN AT APPROX. 65-70 DEGREES. FOR MAGIC SWING REFER TO INHIBIT SWITCH BEA PT# 10 SSINHL OR 10SSINHR
 2) SHOWN LH,RH MAGIC SWING AND RH MAGIC FORCE FOR LH MAGIC FORCE REVERSE RED AND BLACK WIRES.
 3) DOOR CONTROL SW2 SWITCH BANK SET DIPSWITCH # 1 & 3 TO THE OFF (TIMER) POSITION.
 4) LO21S DIPSWITCHES: 1-5 (LOCK-OUT TIMING), #6-8 (NOT USED)
 5) STALL ADJUSTMENTS MAY NEED TO BE INCREASED FOR LO21S OPTIMUM OPERATION.

IF AFTER TROUBLESHOOTING A PROBLEM, A SATISFACTORY SOLUTION CANNOT BE ACHIEVED, PLEASE CALL B.E.A., INC. FOR FURTHER ASSISTANCE DURING EASTERN STANDARD TIME AT 1-800-523-2462 FROM 8AM - 5PM. FOR AFTER-HOURS, CALL EAST COAST: 1-866-836-1863 OR 1-800-407-4545 / MID-WEST: 1-888-308-8843 / WEST COAST: 1-888-419-2564. DO NOT LEAVE ANY PROBLEM UNRESOLVED. IF YOU MUST WAIT FOR THE FOLLOWING WORKDAY TO CALL B.E.A., LEAVE THE DOOR INOPERABLE UNTIL SATISFACTORY REPAIRS CAN BE MADE. NEVER SACRIFICE THE SAFE OPERATION OF THE AUTOMATIC DOOR OR GATE FOR AN INCOMPLETE SOLUTION.WEB: WWW.BEASENSORS.COM

BEA
 We open up New Horizons
 HANAMA GROUP COMPANY

100 ENTERPRISE DRIVE
 PITTSBURGH, PA 15275
 PHONE: (412) 249-4100
 FAX: (412) 249-4101
 EMAIL: www.beasensors.com

TITLE: STANLEY MP CONTROL, MAGIC FORCE, WITH LO-21S, PARALLAX II SYSTEM Q-DISCONNECT ON APPROACH SIDE

SIZE: B	DRAWN BY: KJG	REV BY: KJG	PART NO: 80.0148.01
SCALE: NONE	DATE: 16 NOV 2005	SHEET: 1 OF 1	

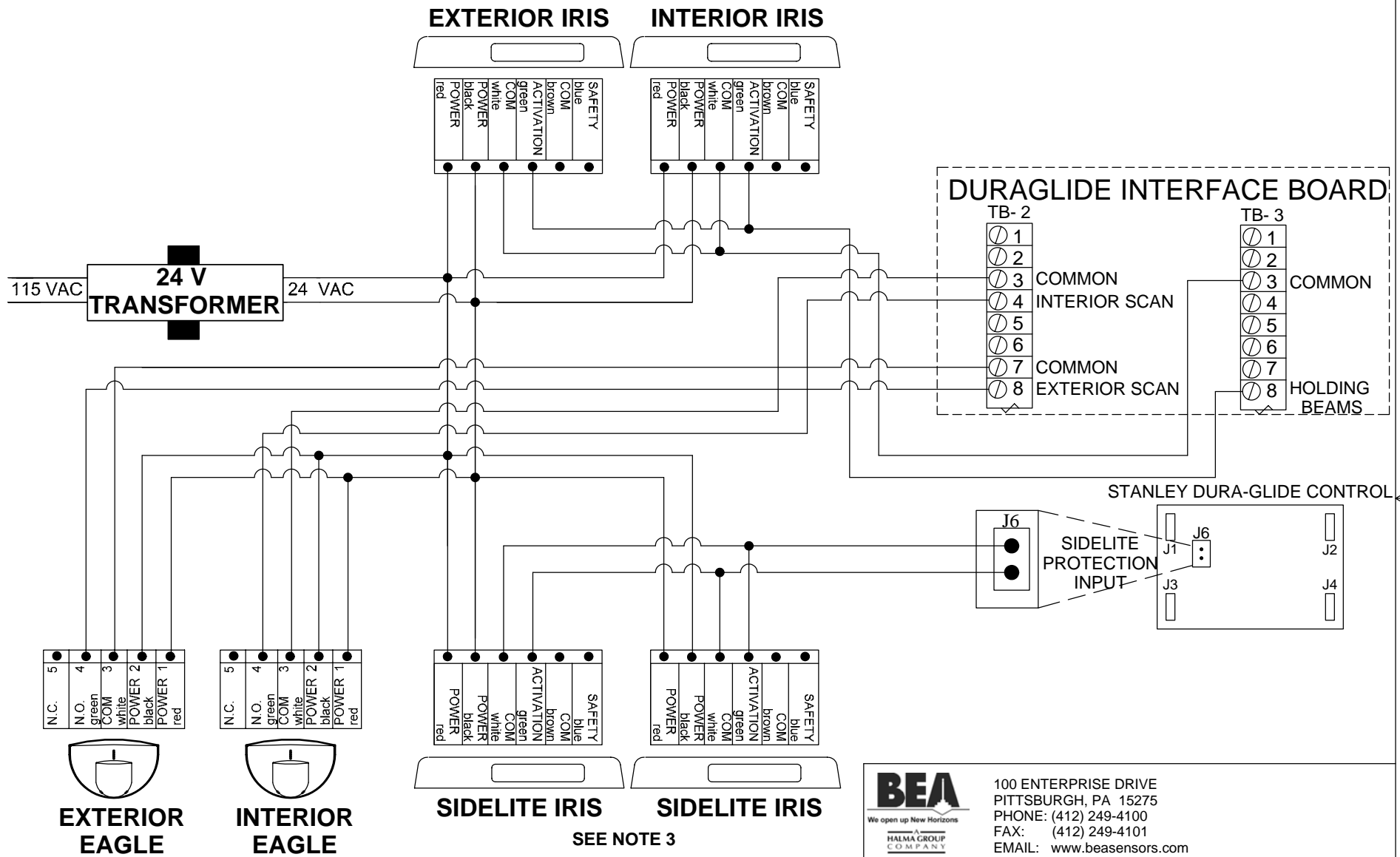

- NOTES: 1) WIZARDS WILL OPERATE WITH THE 12 VDC ON PINS 1&2, 5&6.
 2) ONE WAY FUNCTION IS APPLICABLE IF CLOSED DOOR MONITORING SWITCH IS INSTALLED.
 3) SIDELITE IRIS MAY REQUIRE SPECIAL LENS PART # 10LENS 91214 FTW OR SIMILAR

IF AFTER TROUBLESHOOTING A PROBLEM, A SATISFACTORY SOLUTION CANNOT BE ACHIEVED, PLEASE CALL B.E.A., INC. FOR FURTHER ASSISTANCE DURING EASTERN STANDARD TIME AT 1-800-523-2462 FROM 8AM - 5PM. FOR AFTER-HOURS, CALL EAST COAST: 1-866-836-1863 OR 1-800-407-4545 / MID-WEST: 1-888-308-8843 / WEST COAST: 1-888-419-2564. DO NOT LEAVE ANY PROBLEM UNRESOLVED. IF YOU MUST WAIT FOR THE FOLLOWING WORKDAY TO CALL B.E.A., LEAVE THE DOOR INOPERABLE UNTIL SATISFACTORY REPAIRS CAN BE MADE. NEVER SACRIFICE THE SAFE OPERATION OF THE AUTOMATIC DOOR OR GATE FOR AN INCOMPLETE SOLUTION. WEB: WWW.BEASENSORS.COM



100 ENTERPRISE DRIVE
 PITTSBURGH, PA 15275
 PHONE: (412) 249-4100
 FAX: (412) 249-4101
 EMAIL: www.beasensors.com

TITLE: STANLEY DURAGLIDE WITH EAGLE, IRIS AND IRIS SIDELITE PROTECTION

SIZE: A	DRAWN BY: KJG	REV BY: TUC	PART NO: 80.0155.02
	SCALE: NONE	DATE: 29 NOV 2005	SHEET 1 OF 1

EXTERIOR EAGLE

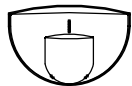

INTERIOR EAGLE

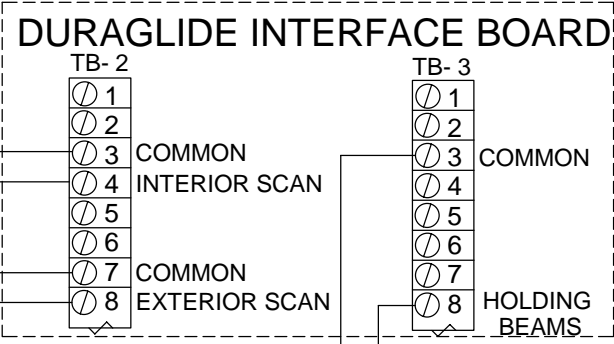
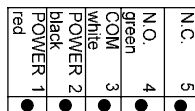
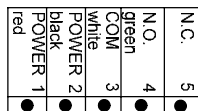
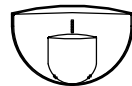

* RECEIVER (A), EMITTER (A)
RECEIVER (B), EMITTER (B)
WH= WHITE, BL= BLACK

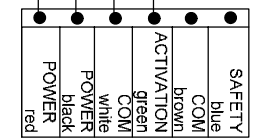
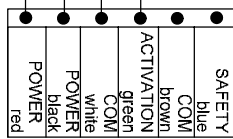
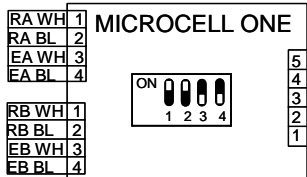

EXTERIOR IRIS

INTERIOR IRIS

IF AFTER TROUBLESHOOTING A PROBLEM, A SATISFACTORY SOLUTION CANNOT BE ACHIEVED, PLEASE CALL B.E.A., INC. FOR FURTHER ASSISTANCE DURING EASTERN STANDARD TIME AT 1-800-523-2462 FROM 8AM - 5PM. FOR AFTER-HOURS, CALL EAST COAST: 1-866-836-1863 OR 1-800-407-4545 / MID-WEST: 1-888-308-8843 / WEST COAST: 1-888-419-2564. DO NOT LEAVE ANY PROBLEM UNRESOLVED. IF YOU MUST WAIT FOR THE FOLLOWING WORKDAY TO CALL B.E.A., LEAVE THE DOOR INOPERABLE UNTIL SATISFACTORY REPAIRS CAN BE MADE. NEVER SACRIFICE THE SAFE OPERATION OF THE AUTOMATIC DOOR OR GATE FOR AN INCOMPLETE SOLUTION.WEB: WWW.BEASENSORS.COM



100 ENTERPRISE DRIVE
PITTSBURGH, PA 15275
PHONE: (412) 249-4100
FAX: (412) 249-4101
EMAIL: www.beasensors.com

TITLE: STANLEY DURAGLIDE WITH EAGLE, IRIS, MICROCELL1

SIZE: A	DRAWN BY: KJG	REV BY: TUC	PART NO: 80.0168.02
	SCALE: NONE	DATE: 01 DEC 2005	SHEET 1 OF 1

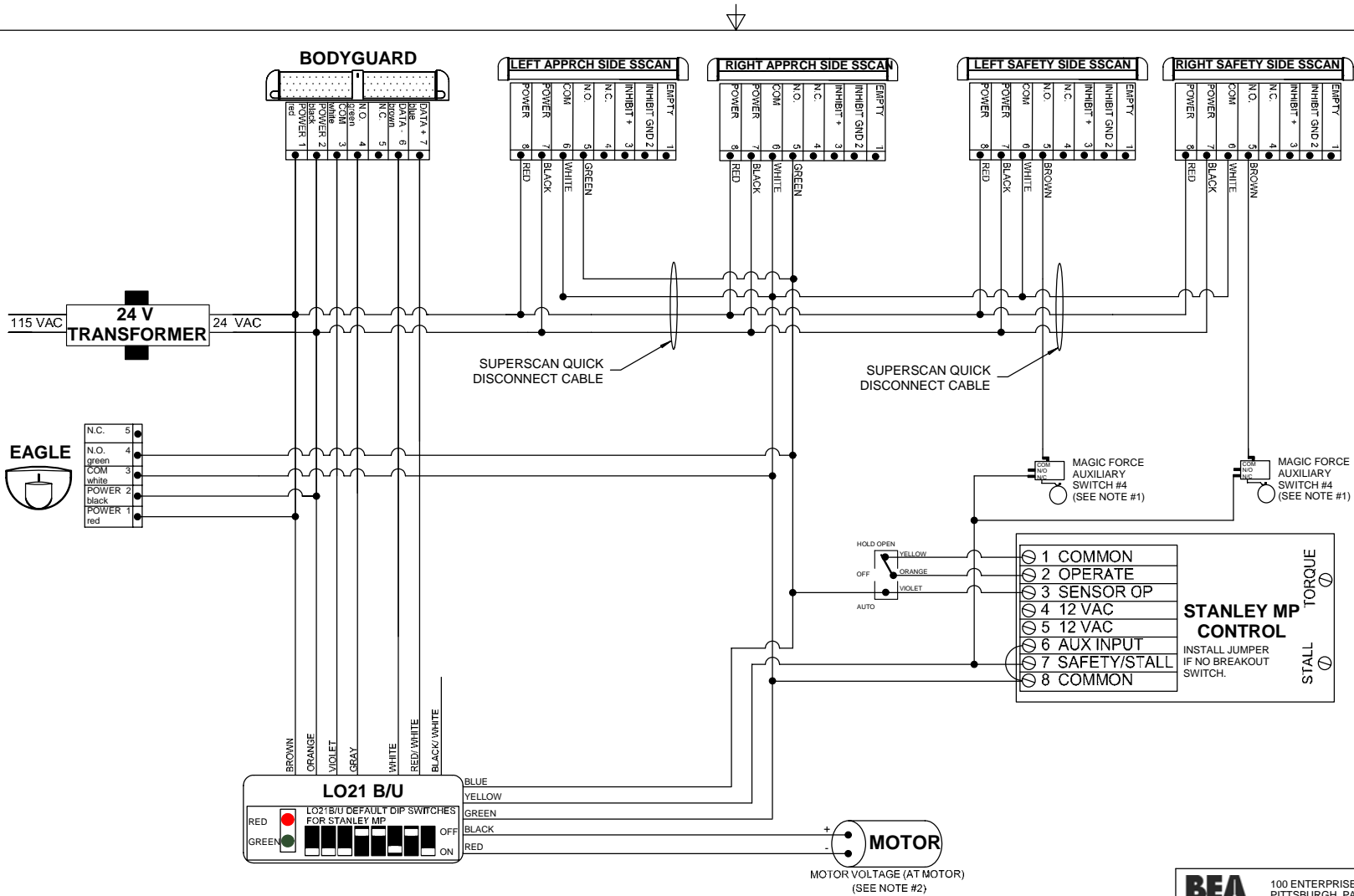

- NOTES: 1) MAGIC FORCE AUX. SWITCH #4 SHOULD OPEN AT APPROX. 65-70 DEGREES. FOR MAGIC SWING REFER TO INHIBIT SWITCH BEA PT# 10 SSINHL OR 10SSINHR
 2) SHOWN LH,RH MAGIC SWING AND RH MAGIC FORCE FOR LH MAGIC FORCE REVERSE RED AND BLACK LO21B/U WIRES.
 3) DOOR CONTROL SW2 SWITCH BANK SET DIPSWITCH # 1 & 3 TO THE OFF (TIMER) POSITION.
 4) LO21U DIPSWITCHES: #1-5 (LOCK-OUT TIMING), #6 (DOWN/ON), #7 (UP/OFF), #8 (DOWN/ON)

IF AFTER TROUBLESHOOTING A PROBLEM, A SATISFACTORY SOLUTION CANNOT BE ACHIEVED, PLEASE CALL B.E.A., INC. FOR FURTHER ASSISTANCE DURING EASTERN STANDARD TIME AT 1-800-523-2462 FROM 8AM - 5PM. FOR AFTER-HOURS, CALL EAST COAST: 1-866-836-1863 OR 1-800-407-4545 / MID-WEST: 1-888-308-8843 / WEST COAST: 1-888-419-2564. DO NOT LEAVE ANY PROBLEM UNRESOLVED. IF YOU MUST WAIT FOR THE FOLLOWING WORKDAY TO CALL B.E.A., LEAVE THE DOOR INOPERABLE UNTIL SATISFACTORY REPAIRS CAN BE MADE. NEVER SACRIFICE THE SAFE OPERATION OF THE AUTOMATIC DOOR OR GATE FOR AN INCOMPLETE SOLUTION.WEB: WWW.BEASENSORS.COM

BEA
 We open up New Horizons
 HALMA GROUP COMPANY
 100 ENTERPRISE DRIVE
 PITTSBURGH, PA 15275
 PHONE: (412) 249-4100
 FAX: (412) 249-4101
 EMAIL: www.beasensors.com

TITLE: STANLEY MAGIC FORCE WITH PARALLAX 2 SYSTEM (LO21B/U), Q-DISCONNECT ON APPROACH SIDE

SIZE: B	DRAWN BY: KJG	REV BY: TUC	PART NO: 80.0170.01
SCALE: NONE	DATE: 01 DEC 2005	SHEET 1 OF 1	

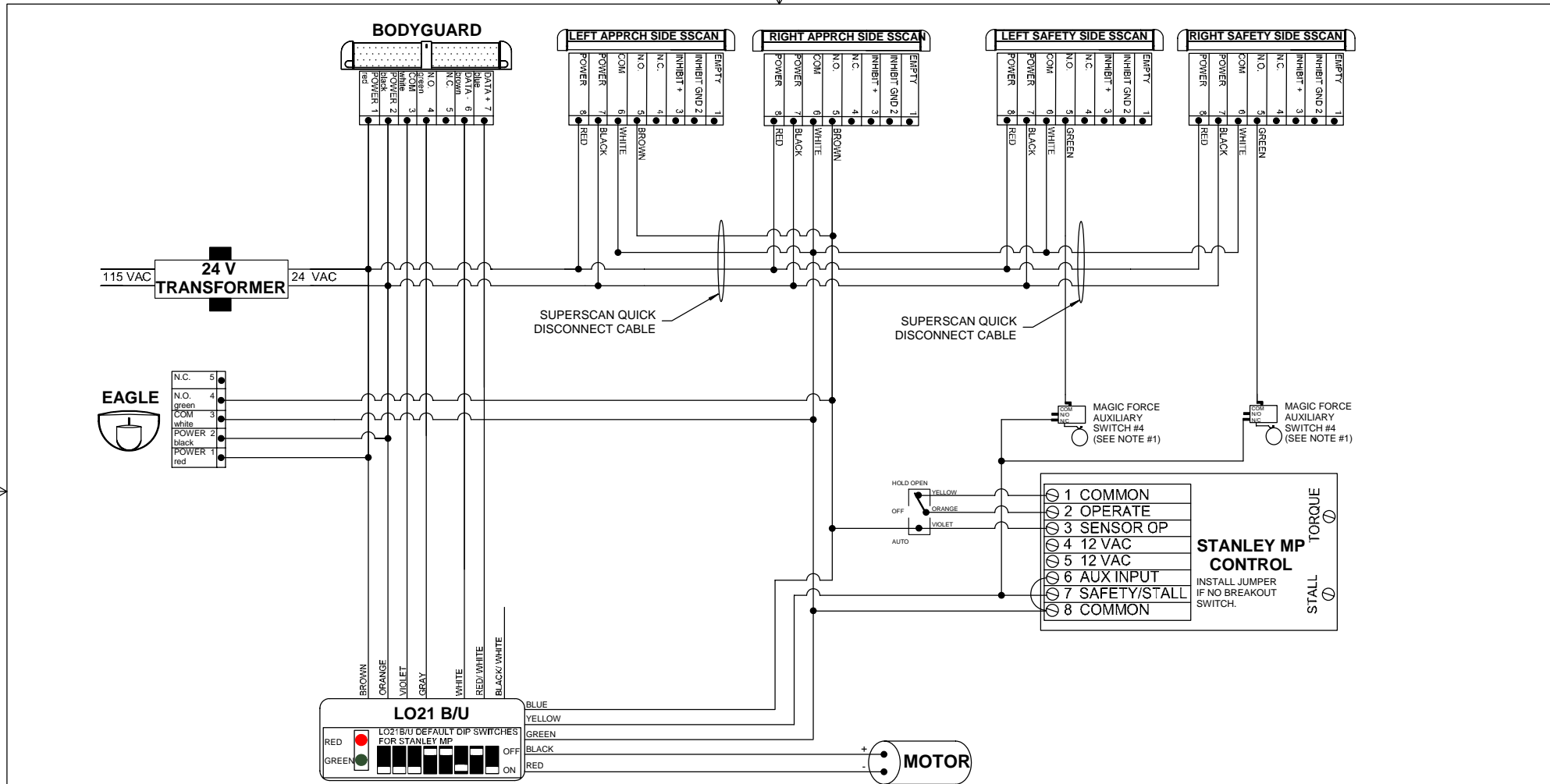

- NOTES: 1) MAGIC FORCE AUX. SWITCH #4 SHOULD OPEN AT APPROX. 65-70 DEGREES. FOR MAGIC SWING REFER TO INHIBIT SWITCH BEA PT# 10 SSINHL OR 10SSINHR
 2) SHOWN LH,RH MAGIC SWING AND RH MAGIC FORCE FOR LH MAGIC FORCE REVERSE RED AND BLACK LO21B/U WIRES.
 3) DOOR CONTROL SW2 SWITCH BANK SET DIPSWITCH # 1 & 3 TO THE OFF (TIMER) POSITION.
 4) LO21U DIPSWITCHES: #1-5 (LOCK-OUT TIMING), #6 (DOWN/ON), #7 (UP/OFF), #8 (DOWN/ON)

IF AFTER TROUBLESHOOTING A PROBLEM, A SATISFACTORY SOLUTION CANNOT BE ACHIEVED, PLEASE CALL B.E.A., INC. FOR FURTHER ASSISTANCE DURING EASTERN STANDARD TIME AT 1-800-523-2462 FROM 8AM - 5PM. FOR AFTER-HOURS, CALL EAST COAST: 1-866-836-1863 OR 1-800-407-4545 / MID-WEST: 1-888-308-8843 / WEST COAST: 1-888-419-2564. DO NOT LEAVE ANY PROBLEM UNRESOLVED. IF YOU MUST WAIT FOR THE FOLLOWING WORKDAY TO CALL B.E.A., LEAVE THE DOOR INOPERABLE UNTIL SATISFACTORY REPAIRS CAN BE MADE. NEVER SACRIFICE THE SAFE OPERATION OF THE AUTOMATIC DOOR OR GATE FOR AN INCOMPLETE SOLUTION.WEB: WWW.BEASENSORS.COM

BEA
 We open up New Horizons
 HANAMA GROUP COMPANY

100 ENTERPRISE DRIVE
 PITTSBURGH, PA 15275
 PHONE: (412) 249-4100
 FAX: (412) 249-4101
 EMAIL: www.beasensors.com

TITLE: STANLEY MAGIC FORCE WITH PARALLAX 2 SYSTEM (LO21B/U), Q-DISCONNECT ON SAFETY SIDE

SIZE: B	DRAWN BY: KJG	REV BY: TUC	PART NO: 80.0171.02
SCALE: NONE	DATE: 01 DEC 2005	SHEET 1 OF 1	

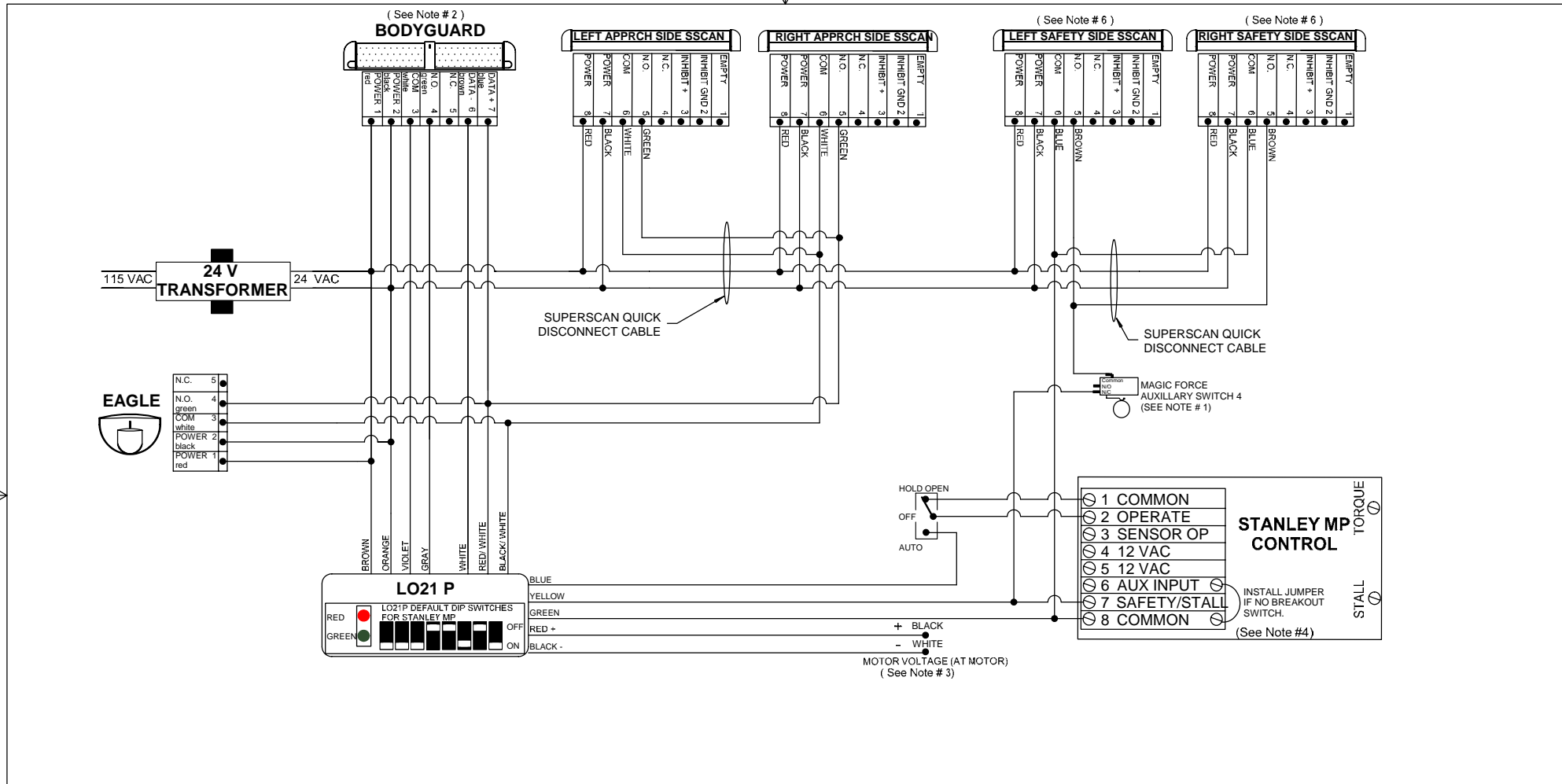

- NOTES: 1) MAGIC FORCE AUX. SWITCH #4 SHOULD OPEN AT APPROX. 65-70 DEGREES. FOR MAGIC SWING REFER TO INHIBIT SWITCH BEA PT# 10 SSSINHL OR 10SSINHR.
 2) THE BODYGUARD RELAY OUTPUT FUNCTION MUST BE CHANGED TO #2.
 3) SHOWN LH,RH MAGIC SWING AND RH MAGIC FORCE FOR LH MAGIC FORCE REVERSE RED AND BLACK WIRES.
 4) DOOR CONTROL SW2 SWITCH BANK SET DIPSWITCH # 1 & 3 TO THE OFF (TIMER) POSITION.
 5) JUMPER 6 & 8.
 6) INSTALL BLUE WIRE INTO PIN 6. INSTALL WHITE WIRE INTO PIN 1

IF AFTER TROUBLESHOOTING A PROBLEM, A SATISFACTORY SOLUTION CANNOT BE ACHIEVED, PLEASE CALL B.E.A., INC. FOR FURTHER ASSISTANCE DURING EASTERN STANDARD TIME AT 1-800-523-2462 FROM 8AM - 5PM. FOR AFTER-HOURS, CALL EAST COAST: 1-866-836-1863 OR 1-800-407-4545 / MID-WEST: 1-888-308-8843 / WEST COAST: 1-888-419-2564. DO NOT LEAVE ANY PROBLEM UNRESOLVED. IF YOU MUST WAIT FOR THE FOLLOWING WORKDAY TO CALL B.E.A., LEAVE THE DOOR INOPERABLE UNTIL SATISFACTORY REPAIRS CAN BE MADE. NEVER SACRIFICE THE SAFE OPERATION OF THE AUTOMATIC DOOR OR GATE FOR AN INCOMPLETE SOLUTION.WEB: WWW.BEASENSORS.COM

		100 ENTERPRISE DRIVE PITTSBURGH, PA 15275 PHONE: (412) 249-4100 FAX: (412) 249-4101 EMAIL: www.beasensors.com	
		TITLE: STANLEY MP CONTROL WITH LO-21P PARALLAX II SYSTEM Q-DISCONNECT ON APPROACH SIDE	
SIZE: B	DRAWN BY: KJG	REV BY: TUC	PART NO: 80.0187.04
SCALE: NONE	DATE: 02 DEC 2005	SHEET: 1 OF 1	

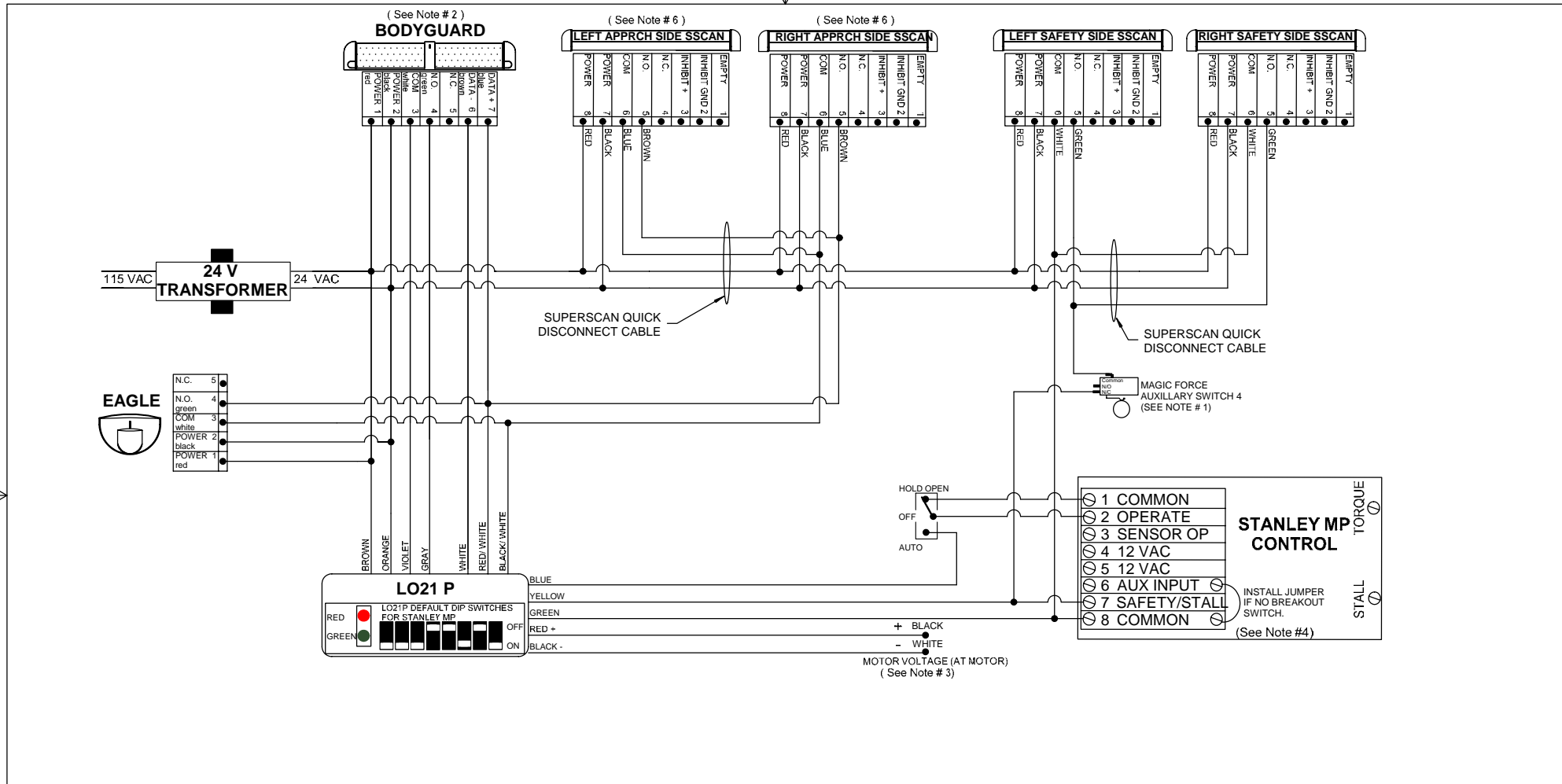

- NOTES: 1) MAGIC FORCE AUX. SWITCH #4 SHOULD OPEN AT APPROX. 65-70 DEGREES. FOR MAGIC SWING REFER TO INHIBIT SWITCH BEA PT# 10 SSSINHL OR 10SSINHR.
 2) THE BODYGUARD RELAY OUTPUT FUNCTION MUST BE CHANGED TO #2.
 3) SHOWN LH,RH MAGIC SWING AND RH MAGIC FORCE FOR LH MAGIC FORCE REVERSE RED AND BLACK WIRES.
 4) DOOR CONTROL SW2 SWITCH BANK SET DIPSWITCH # 1 & 3 TO THE OFF (TIMER) POSITION.
 5) JUMPER 6 & 8.
 6) INSTALL BLUE WIRE INTO PIN 6. INSTALL WHITE WIRE INTO PIN 1

IF AFTER TROUBLESHOOTING A PROBLEM, A SATISFACTORY SOLUTION CANNOT BE ACHIEVED, PLEASE CALL B.E.A., INC. FOR FURTHER ASSISTANCE DURING EASTERN STANDARD TIME AT 1-800-523-2462 FROM 8AM - 5PM. FOR AFTER-HOURS, CALL EAST COAST: 1-866-836-1863 OR 1-800-407-4545 / MID-WEST: 1-888-308-8843 / WEST COAST: 1-888-419-2564. DO NOT LEAVE ANY PROBLEM UNRESOLVED. IF YOU MUST WAIT FOR THE FOLLOWING WORKDAY TO CALL B.E.A., LEAVE THE DOOR INOPERABLE UNTIL SATISFACTORY REPAIRS CAN BE MADE. NEVER SACRIFICE THE SAFE OPERATION OF THE AUTOMATIC DOOR OR GATE FOR AN INCOMPLETE SOLUTION.WEB: WWW.BEASENSORS.COM

		100 ENTERPRISE DRIVE PITTSBURGH, PA 15275 PHONE: (412) 249-4100 FAX: (412) 249-4101 EMAIL: www.beasensors.com	
		TITLE: STANLEY MP CONTROL WITH LO-21P PARALLAX II SYSTEM Q-DISCONNECT ON SAFETY SIDE	
SIZE: B	DRAWN BY: KJG	REV BY: TUC	PART NO: 80.0188.04
SCALE: NONE	DATE: 02 DEC 2005	SHEET 1 OF 1	

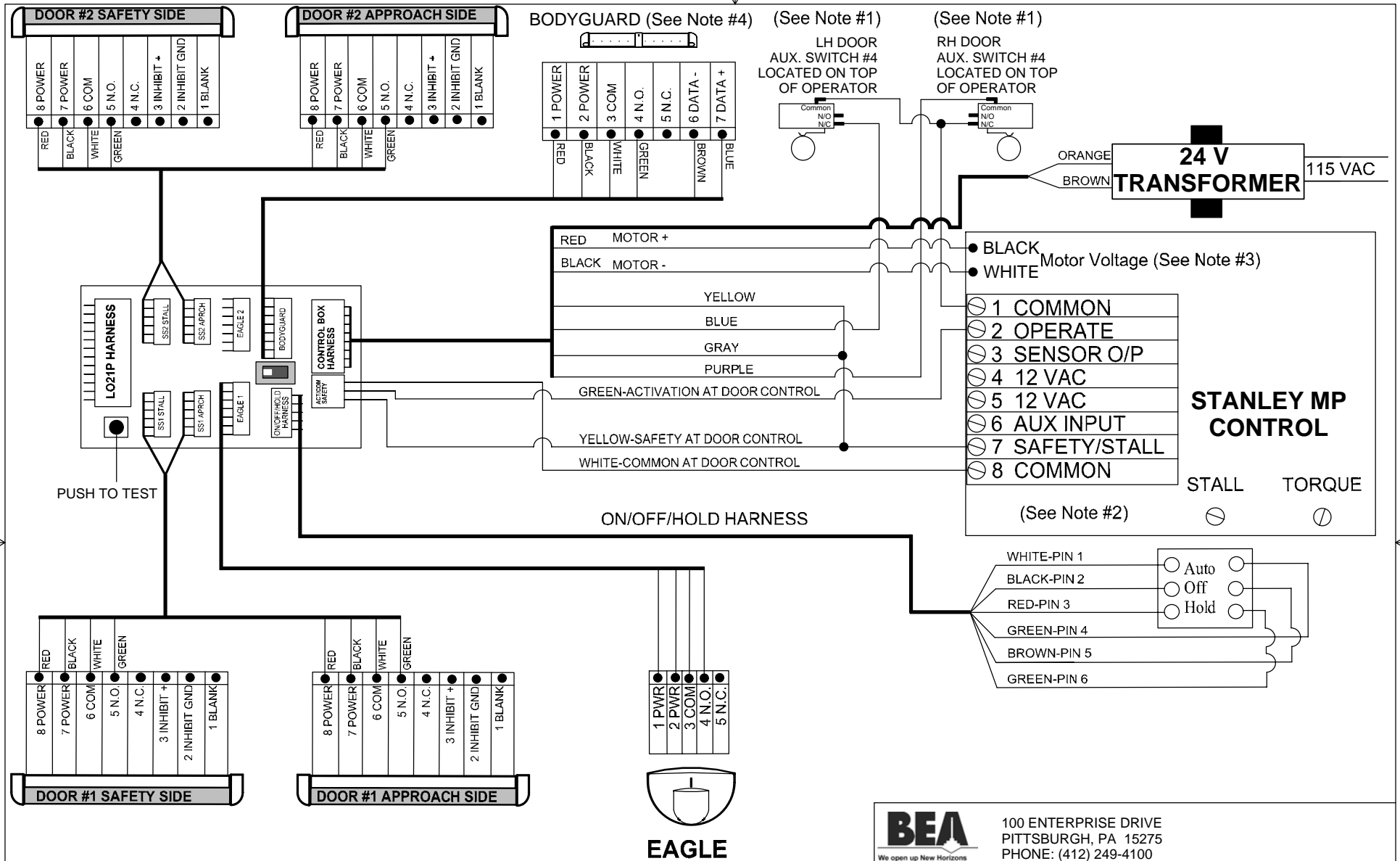

- NOTES: 1) MAGIC FORCE AUX. SWITCH #4 SHOULD OPEN AT APPROX. 65-70 DEGREES. FOR MAGIC SWING REFER TO INHIBIT SWITCH BEA PT# 10 SSINHL OR 10SSINHR.
 2) DOOR CONTROL SW2 SWITCH BANK SET DIPSWITCH # 1 & 3 TO THE OFF (TIMER) POSITION.
 3) RH MOTOR SHOWN, REVERSE MOTOR SWITCH ON PARALINK FOR LH MOTOR.
 4) BODYGUARD MUST BE PROGRAMMED TO RELAY VALUE 2. DEFAULT IS 1.
 5) INSTALL JUMPER AT CONTROL ON TERMINAL 6 & 8 IF NO BREAKOUT SWITCH.

IF AFTER TROUBLESHOOTING A PROBLEM, A SATISFACTORY SOLUTION CANNOT BE ACHIEVED, PLEASE CALL B.E.A., INC. FOR FURTHER ASSISTANCE DURING EASTERN STANDARD TIME AT 1-800-523-2462 FROM 8AM - 5PM. FOR AFTER-HOURS, CALL EAST COAST: 1-866-836-1863 OR 1-800-407-4545 / MID-WEST: 1-888-308-8843 / WEST COAST: 1-888-419-2564. DO NOT LEAVE ANY PROBLEM UNRESOLVED. IF YOU MUST WAIT FOR THE FOLLOWING WORKDAY TO CALL B.E.A., LEAVE THE DOOR INOPERABLE UNTIL SATISFACTORY REPAIRS CAN BE MADE. NEVER SACRIFICE THE SAFE OPERATION OF THE AUTOMATIC DOOR OR GATE FOR AN INCOMPLETE SOLUTION. WEB: WWW.BEASENSORS.COM



100 ENTERPRISE DRIVE
 PITTSBURGH, PA 15275
 PHONE: (412) 249-4100
 FAX: (412) 249-4101
 EMAIL: www.beasensors.com

TITLE: PARALLINK, STANLEY MP CONTROL, MAGIC FORCE OPERATOR

SIZE: A	DRAWN BY: TUC	REV BY: TUC	PART NO: 80.0203.01
	SCALE: NONE	DATE: 19 SEP 2005	SHEET 1 OF 1

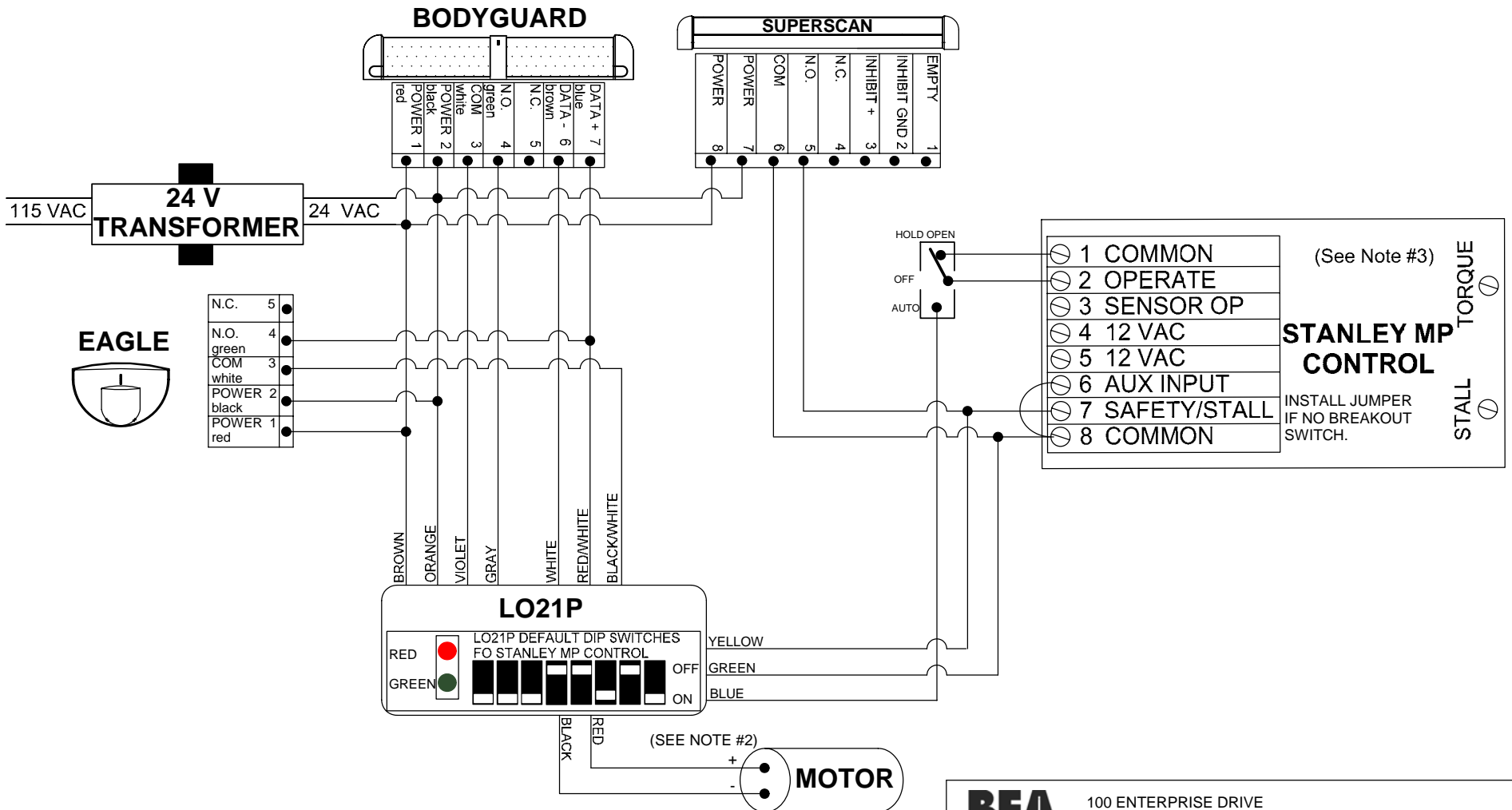

NOTES: 1) THE BODYGUARD RELAY OUTPUT FUNCTION MUST BE CHANGED TO #2.
 2) SHOWN LH,RH MAGIC SWING AND RH MAGIC FORCE FOR LH MAGIC FORCE REVERSE RED AND BLACK WIRES.
 3) DOOR CONTROL SW2 SWITCH BANK SET DIPSWITCH #1 & 3 TO THE ON POSITION.

IF AFTER TROUBLESHOOTING A PROBLEM, A SATISFACTORY SOLUTION CANNOT BE ACHIEVED, PLEASE CALL B.E.A., INC. FOR FURTHER ASSISTANCE DURING EASTERN STANDARD TIME AT 1-800-523-2462 FROM 8AM - 5PM. FOR AFTER-HOURS, CALL EAST COAST: 1-866-836-1863 OR 1-800-407-4545 / MID-WEST: 1-888-308-8843 / WEST COAST: 1-888-419-2564. DO NOT LEAVE ANY PROBLEM UNRESOLVED. IF YOU MUST WAIT FOR THE FOLLOWING WORKDAY TO CALL B.E.A., LEAVE THE DOOR INOPERABLE UNTIL SATISFACTORY REPAIRS CAN BE MADE. NEVER SACRIFICE THE SAFE OPERATION OF THE AUTOMATIC DOOR OR GATE FOR AN INCOMPLETE SOLUTION.WEB: WWW.BEASENSORS.COM



100 ENTERPRISE DRIVE
 PITTSBURGH, PA 15275
 PHONE: (412) 249-4100
 FAX: (412) 249-4101
 EMAIL: www.beasensors.com

**TITLE: STANLEY MP CONTROL WITH
 LO-21P, BODYGUARD, EAGLE**

SIZE: A	DRAWN BY: TUC	REV BY: TUC	PART NO: 80.0212.01
	SCALE: NONE	DATE: 18 OCT 2005	SHEET 1 OF 1

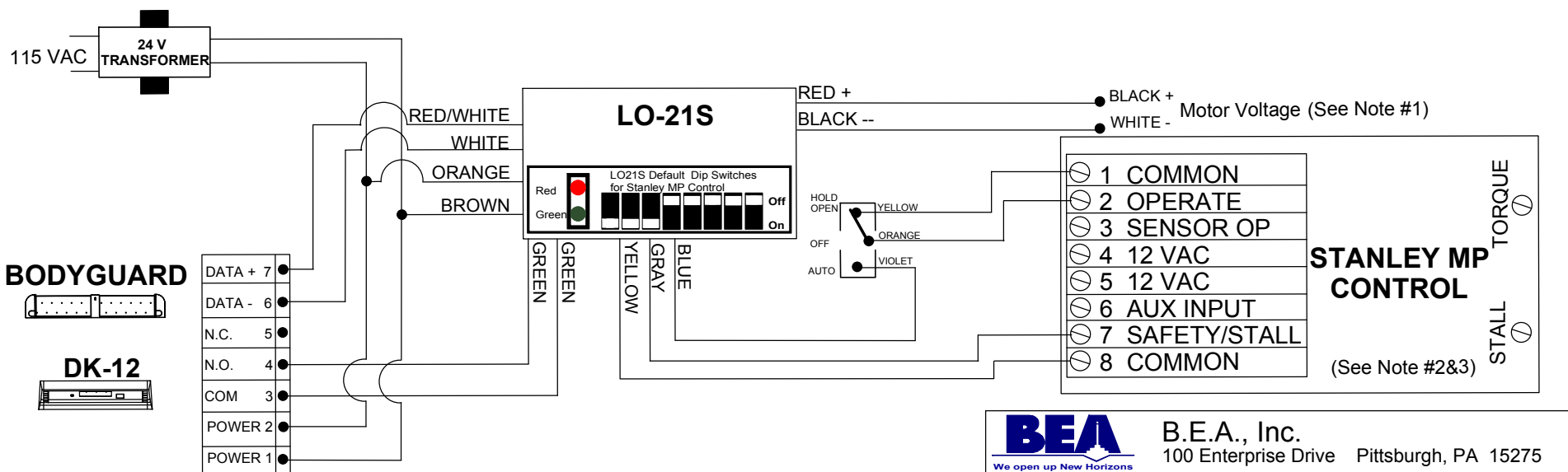
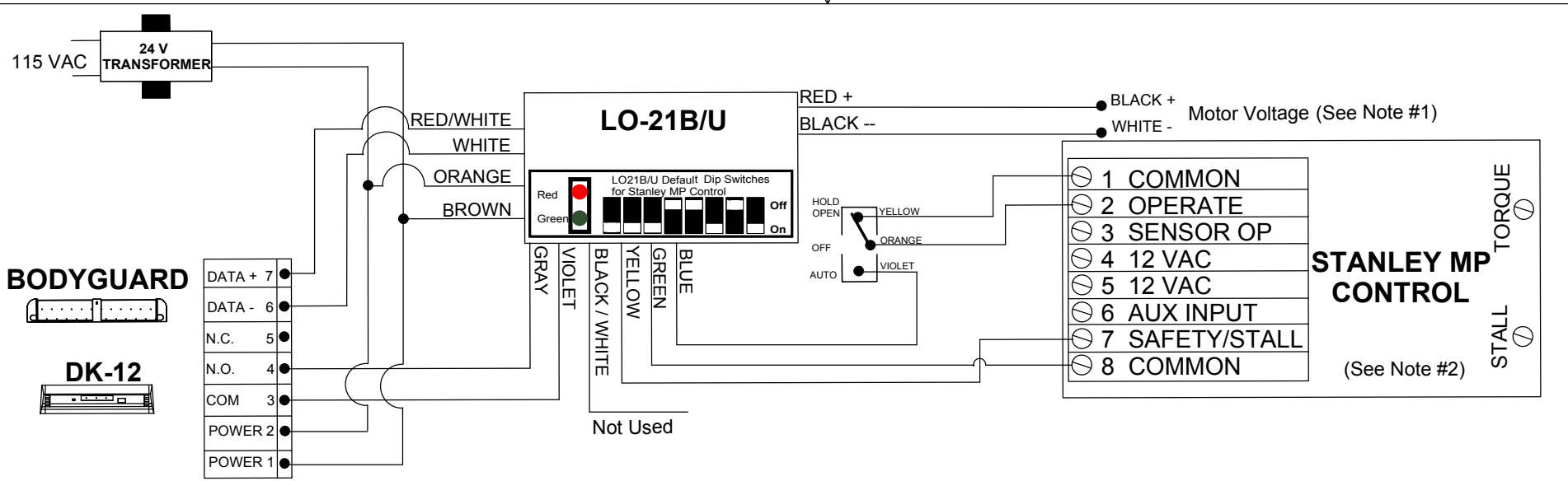

- NOTE:
- 1.) SHOWN LH,RH MAGIC SWING AND RH MAGIC FORCE FOR LH MAGIC FORCE REVERSE RED AND BLACK WIRES.
 - 2.) DOOR CONTROL SW2 SWITCH BANK SET DIPSWITCH #1 & 3 TO THE ON POSITION.
 - 3.) TORQUE IF APPLICABLE AND STALL ADJUSTMENTS MAY NEED TO BE INCREASED FOR LO21S/U PROPER OPERATION.

BEA
We open up New Horizons
HALMA GROUP COMPANY

B.E.A., Inc.
100 Enterprise Drive Pittsburgh, PA 15275
PH: (412) 249-4100 FAX: (412) 249-4101
www.beasensors.com

**TITLE: STANLEY MP CONTROL
LO21U, LO21S, BODYGUARD**

SIZE A	CAGE CODE	DWG NO	FILE OF: JED	DRAWN BY: JED	REV .
SCALE	DATE: 13 JAN 2004		SHEET 1 OF 1		

LO-LINX SWING	GREEN ACT.	WHITE COM.	YELLOW SAF.	BLUE STALL	BROWN STAL COM.
BESAM 300	13	12	11	15, 17	16, 18
BESAM M/P	3	4	9	5	13
DOM	YELLOW	GREY	BLUE	PURPLE	GREY
GT 300/400	BLACK	RED	WHITE	WHITE	RED
GT MAG	6 BLACK	5 RED	4 WHITE	3 VIOLET	5 RED
HORTON 4190	2	3, 6, 8	4	10	3, 6, 8
HUNTER	ACT.	RTN	SAF. 1	SAF. 2	RTN
KM K	GREEN	WHITE	RED	YELLOW	WHITE
STANLEY "L"	ORANGE	YELLOW	RED	BLUE	YELLOW
STANLEY M/P	2	1, 8	7	7	1, 8
STANLEY 521	TB4-5	TB4-4	TB4-8	TB4-10	TB4-9
TORMAX TDA	2	1, 3, 6, 8	8 & 9	7	1, 3, 6, 8

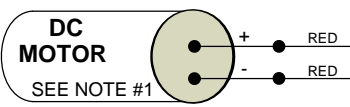
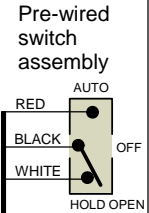
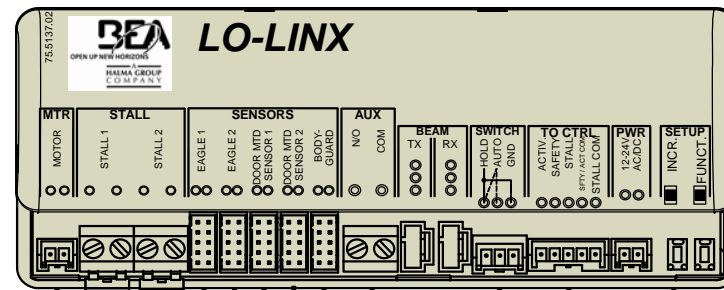

LO-LINX MOTOR HARNESS p/n: 20.5076

SEE NOTE #2

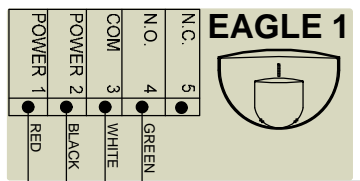

LO-LINX EAGLE HARNESS p/n: 20.5096

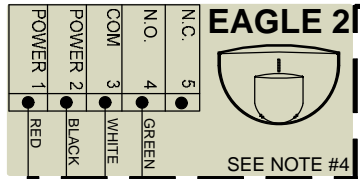

SEE NOTE #4

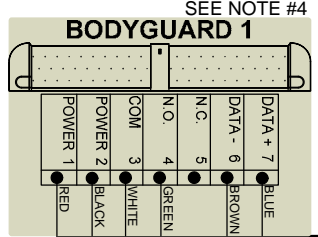

SEE NOTE #4

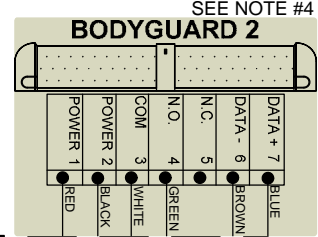

SEE NOTE #4

LO-LINX SUPERSCAN HARNESS p/n: 70.5071

LO-LINX CONTROL HARNESS p/n: 20.5097

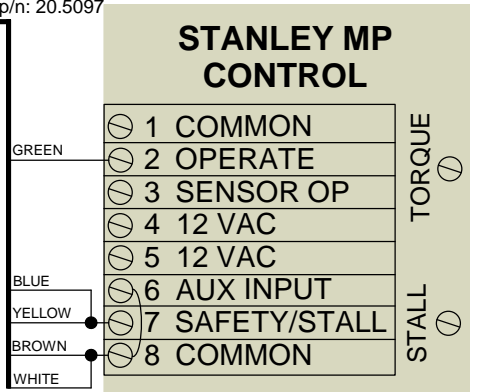

SEE NOTE #5

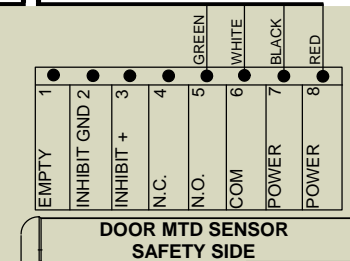
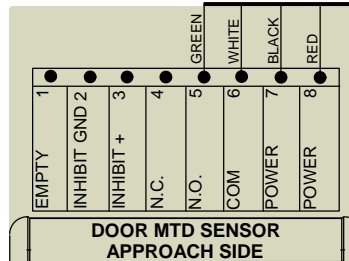
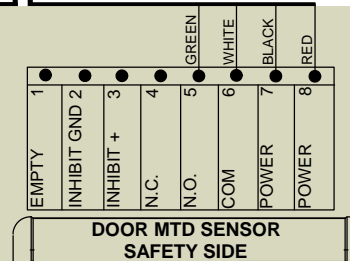
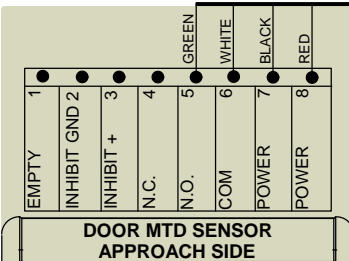

- NOTES:
1. MOTOR CONNECTION IS TIED IN PARALLEL TO EXISTING MOTOR LEADS. NO RESPECT TO POLARITY IS REQUIRED.
 2. EXTERNAL SWITCHES ARE REQUIRED IF INHIBIT IS DESIRED AT SWING SIDE SUPERSCANS, SWITCH OPENS UPON INHIBIT POINT. IF USING MAGIC FORCE, AUX. CAM SWITCH 4 CAN BE USE TO INHIBIT. MAGIC SWING BREAKOUT SWITCHES CAN BE USED IF THEY ARE NOT NEEDED FOR BREAKOUT.
 3. THE KNOWING ACT SWITCH IS CONNECTED AT THE AUX INPUT AND CAN BE ANY DRY CONTACT DEVICE SUCH AS A PUSHPLATE, CARD READER, ETC. THE AUX INPUT IS REQUIRED FOR ALL INITIAL ACTIVATION WHEN FUNCTION 'FA' ON THE LO-LINX IS SET TO '01'.
 4. THE SECOND BODYGUARD AND EAGLE ARE PRIMARILY USED IN DUAL-EGRESS APPLICATIONS. ENSURE BODYGUARD RELAY VALUE IS SET TO 2.
 5. INSERTING A JUMPER ON THE CONTROL TERMINAL # 6 & 8 MAY BE NECESSARY IF NO BREAKOUT SWITCHES ARE ENABLED.

Do not leave problems unresolved. If a satisfactory solution cannot be achieved after troubleshooting a problem, please call B.E.A., Inc. If you must wait for the following workday to call B.E.A., leave the door inoperable until satisfactory repairs can be made. Never sacrifice the safe operation of the automatic door or gate for an incomplete solution. During EST 8am - 5pm call B.E.A., @ 800-523-2462. After 5pm EST all 866-249-7937 or 866-836-1863. After 5pm CST call 800-407-4545 or 888-308-8843. After 5pm MST or PST call 888-419-2564. Ensure compliance with current applicable standards. i.e. ANSI 156.10.

BEA
OPEN UP NEW HORIZONS
HALMA GROUP COMPANY

100 ENTERPRISE DRIVE
PITTSBURGH, PA 15275
PHONE: (412) 249-4100
FAX: (412) 249-4101
EMAIL: www.beasensors.com

TITLE: LO-LINX SYSTEM
STANLEY MP/HDLE CONTROL

SIZE: A	DRAWN BY: JED	REV BY: TUC	PART NO: 80.0243.04
SCALE: NONE	DATE: 10/15/2007	SHEET 1 OF 1	

LO-LINX SWING	GREEN ACT.	WHITE COM.	YELLOW SAF.	BLUE STALL	BROWN STAL COM.
BESAM 300	13	12	11	15, 17	16, 18
BESAM M/P	3	4	9	5	13
DOM	YELLOW	GREY	BLUE	PURPLE	GREY
GT 300/400	BLACK	RED	WHITE	WHITE	RED
GT MAG	6 BLACK	5 RED	4 WHITE	3 VIOLET	5 RED
HORTON 4190	2	3, 6, 8	4	10	3, 6, 8
HUNTER	ACT.	RTN	SAF. 1	SAF. 2	RTN
KM K	GREEN	WHITE	RED	YELLOW	WHITE
STANLEY "L"	ORANGE	YELLOW	RED	BLUE	YELLOW
STANLEY M/P	2	1, 8	7	7	1, 8
STANLEY 521	TB4-5	TB4-4	TB4-8	TB4-10	TB4-9
TORMAX TDA	2	1, 3, 6, 8	8 & 9	7	1, 3, 6, 8

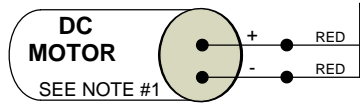
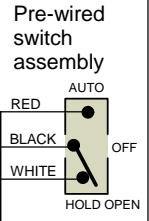
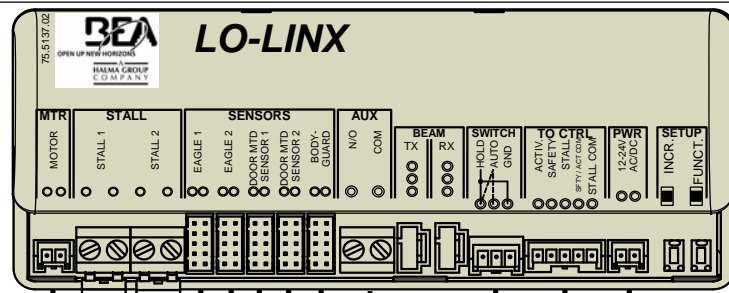

LO-LINX MOTOR HARNESS p/n: 20.5076

SEE NOTE #2

LO-LINX BODYGUARD HARNESS p/n: 20.5082

SEE NOTE #3

LO-LINX HOLD SWITCH HARNESS p/n: 20.5078

LO-LINX CONTROL HARNESS p/n: 20.5097

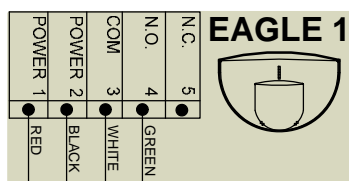

LO-LINX EAGLE HARNESS p/n: 20.5096

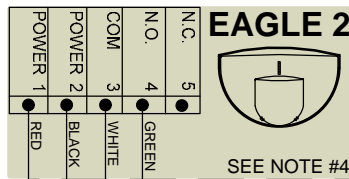

SEE NOTE #4

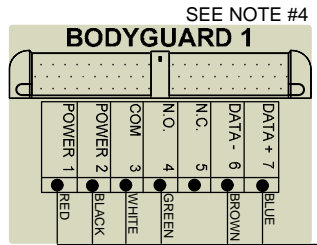

SEE NOTE #4

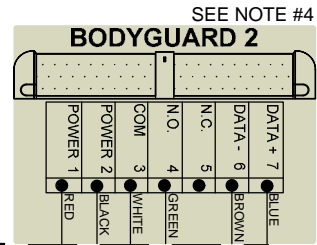

SEE NOTE #4

LO-LINX SUPERSCAN HARNESS p/n: 70.5071

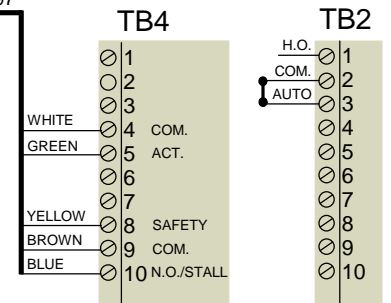

STANLEY 521 CONTROL

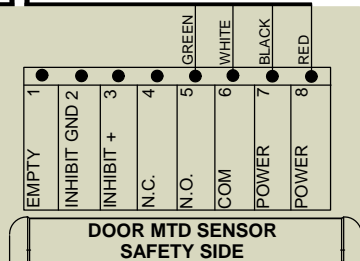
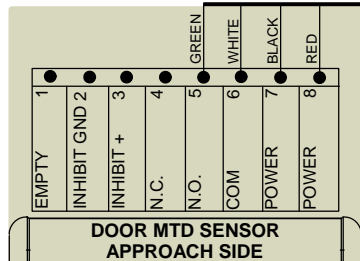
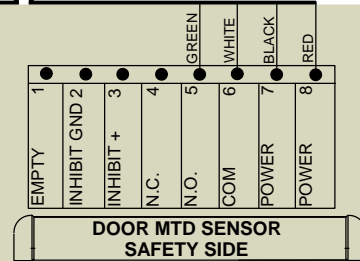
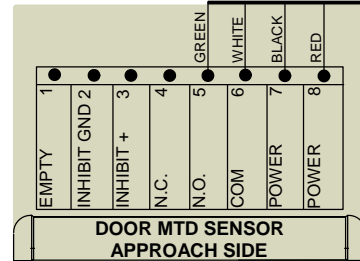

- NOTES:
1. MOTOR CONNECTION IS TIED IN PARALLEL TO EXISTING MOTOR LEADS. NO RESPECT TO PALARITY IS REQUIRED.
 2. EXTERNAL SWITCHES ARE REQUIRED IF INHIBIT DESIRED AT SWING SIDE SUPERSCANS, SWITCH OPENS UPON INHIBIT POINT.
 3. THE KNOWING ACT SWITCH IS CONNECTED AT THE AUX INPUT AND CAN BE ANY DRY CONTACT DEVICE SUCH AS A PUSHPLATE, CARD READER, ETC. THE AUX INPUT IS REQUIRED FOR ALL INITIAL ACTIVATION WHEN FUNCTION 'FA' ON THE LO-LINX IS SET TO '01'.
 4. THE SECOND BODYGUARD AND EAGLE ARE PRIMARILY USED IN DUAL-EGRESS APPLICATIONS. ENSURE BODYGUARD RELAY VALUE IS SET TO 2.

IF AFTER TROUBLESHOOTING A PROBLEM, A SATISFACTORY SOLUTION CANNOT BE ACHIEVED, PLEASE CALL B.E.A., INC. FOR FURTHER ASSISTANCE DURING EASTERN STANDARD TIME AT 1-800-523-2462 FROM 8AM - 5PM. FOR AFTER-HOURS, CALL EAST COAST: 1-866-836-1863 OR 1-800-407-4545 / MID-WEST: 1-888-308-8843 / WEST COAST: 1-888-419-2564. DO NOT LEAVE ANY PROBLEM UNRESOLVED. IF YOU MUST WAIT FOR THE FOLLOWING WORKDAY TO CALL B.E.A., LEAVE THE DOOR INOPERABLE UNTIL SATISFACTORY REPAIRS CAN BE MADE. NEVER SACRIFICE THE SAFE OPERATION OF THE AUTOMATIC DOOR OR GATE FOR AN INCOMPLETE SOLUTION. WEB: WWW.BEASENSORS.COM

100 ENTERPRISE DRIVE
PITTSBURGH, PA 15275
PHONE: (412) 249-4100
FAX: (412) 249-4101
EMAIL: www.beasensors.com

TITLE: STANLEY 521 - LO-LINX SYSTEM

SIZE: A	DRAWN BY: JED	REV BY: TUC	PART NO: 80.0287.00
SCALE: NONE	DATE: 10/15/2007	SHEET 1 OF 1	